

Chroma

LCR Meter
11022
User's Manual



LCR Meter 11022 User's Manual



Version 1.2
July 2013

Legal Notices

The information in this document is subject to change without notice.

Chroma ATE INC. makes no warranty of any kind with regard to this manual, including, but not limited to, the implied warranties of merchantability and fitness for a particular purpose. Chroma ATE INC. shall not be held liable for errors contained herein or direct, indirect, special, incidental or consequential damages in connection with the furnishing, performance, or use of this material.

CHROMA ATE INC.

66 Hwaya 1st Rd., Kueishan Hwaya Technology Park, Taoyuan County 33383, Taiwan

Copyright Notices. Copyright 2008 - 2013 Chroma ATE INC., all rights reserved.
Reproduction, adaptation, or translation of this document without prior written permission is prohibited, except as allowed under the copyright laws.

Warranty

All Chroma instruments are warranted against defects in material and workmanship for a period of one year after date of shipment. Chroma agrees to repair or replace any assembly or component found to be defective, under normal use during this period. Chroma's obligation under this warranty is limited solely to repairing any such instrument, which in Chroma's sole opinion proves to be defective within the scope of the warranty when returned to the factory or to an authorized service center. Purchaser is responsible for the shipping and cost of the service item to Chroma factory or service center. Shipment should not be made without prior authorization by Chroma.

This warranty does not apply to any products repaired or altered by persons not authorized by Chroma, or not in accordance with instructions furnished by Chroma. If the instrument is defective as a result of misuse, improper repair, or abnormal conditions or operations, repairs will be billed at cost.

Chroma assumes no responsibility for its product being used in a hazardous or dangerous manner either alone or in conjunction with other equipment. High voltage used in some instruments may be dangerous if misused. Special disclaimers apply to these instruments. Chroma assumes no liability for secondary charges or consequential damages and in any event, Chroma's liability for breach of warranty under any contract or otherwise, shall not exceed the purchase price of the specific instrument shipped and against which a claim is made.

Any recommendations made by Chroma for use of its products are based upon tests believed to be reliable, but Chroma makes no warranty of the results to be obtained. This warranty is in lieu of all other warranties, expressed or implied, and no representative or person is authorized to represent or assume for Chroma any liability in connection with the sale of our products other than set forth herein.

CHROMA ATE INC.

66 Hwaya 1st Rd., Kueishan Hwaya Technology Park,
Taoyuan County 33383, Taiwan
Tel: 886-3-327-9999
Fax: 886-3-327-2886
e-mail: info@chromaate.com
<http://www.chromaate.com>

Material Contents Declaration

The recycling label shown on the product indicates the Hazardous Substances contained in the product as the table listed below.

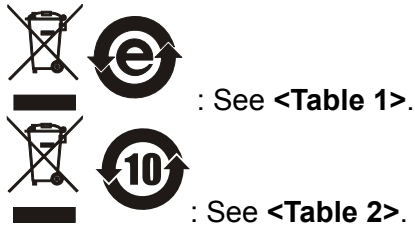

<Table 1>

Part Name	Hazardous Substances					
	Lead	Mercury	Cadmium	Hexavalent Chromium	Polybrominated Biphenyls	Polybromodiphenyl Ethers
	Pb	Hg	Cd	Cr ⁶⁺	PBB	PBDE
PCBA	○	○	○	○	○	○
CHASSIS	○	○	○	○	○	○
ACCESSORY	○	○	○	○	○	○
PACKAGE	○	○	○	○	○	○

“○” indicates that the level of the specified chemical substance is less than the threshold level specified in the standards of SJ/T-11363-2006 and EU 2005/618/EC.

“×” indicates that the level of the specified chemical substance exceeds the threshold level specified in the standards of SJ/T-11363-2006 and EU 2005/618/EC.

Disposal

Do not dispose of electrical appliances as unsorted municipal waste, use separate collection facilities. Contact your local government for information regarding the collection systems available. If electrical appliances are disposed of in landfills or dumps, hazardous substances can leak into the groundwater and get into the food chain, damaging your health and well-being. When replacing old appliances with new one, the retailer is legally obligated to take back your old appliances for disposal at least for free of charge.



<Table 2>

Part Name	Hazardous Substances					
	Lead	Mercury	Cadmium	Hexavalent Chromium	Polybrominated Biphenyls	Polybromodiphenyl Ethers
	Pb	Hg	Cd	Cr ⁶⁺	PBB	PBDE
PCBA	×	○	○	○	○	○
CHASSIS	×	○	○	○	○	○
ACCESSORY	×	○	○	○	○	○
PACKAGE	○	○	○	○	○	○

“○” indicates that the level of the specified chemical substance is less than the threshold level specified in the standards of SJ/T-11363-2006 and EU 2005/618/EC.

“×” indicates that the level of the specified chemical substance exceeds the threshold level specified in the standards of SJ/T-11363-2006 and EU 2005/618/EC.

1. Chroma is not fully transitioned to lead-free solder assembly at this moment; however, most of the components used are RoHS compliant.
2. The environment-friendly usage period of the product is assumed under the operating environment specified in each product’s specification.

Disposal

Do not dispose of electrical appliances as unsorted municipal waste, use separate collection facilities. Contact your local government for information regarding the collection systems available. If electrical appliances are disposed of in landfills or dumps, hazardous substances can leak into the groundwater and get into the food chain, damaging your health and well-being. When replacing old appliances with new one, the retailer is legally obligated to take back your old appliances for disposal at least for free of charge.





Declaration of Conformity

For the following equipment :

LCR Meter

(Product Name/ Trade Name)

11020, 11022, 11025, 11022 Dual Frequency, 11025 Dual Frequency

(Model Designation)

CHROMA ATE INC.

(Manufacturer Name)

66, Hwaya 1st Rd., Kueishan Hwaya Technology Park, Taoyuan County 33383, Taiwan

(Manufacturer Address)

Is herewith confirmed to comply with the requirements set out in the Council Directive on the Approximation of the Laws of the Member States relating to Electromagnetic Compatibility (2004/108/EC) and Low Voltage Directive (2006/95/EC). For the evaluation regarding the Directives, the following standards were applied :

EN 61326-1:2006

EN 55011:1998/A1:1999/A2:2002 Class A, EN 61000-3-2:2006,

EN 61000-3-3:1995/A1:2001/A2:2005, IEC 61000-4-2:1995/A1:1998/A2:2000,

IEC 61000-4-3:2002, IEC 61000-4-4:2004, IEC 61000-4-5:1995/A1:2000,

IEC 61000-4-6:2003, IEC 61000-4-8:1993/A1:2000, IEC 61000-4-11:2004

EN 61010-1:2010(Third Edition)

The following importer/manufacturer or authorized representative established within the EUT is responsible for this declaration :

CHROMA ATE INC.

(Company Name)

66, Hwaya 1st Rd., Kueishan Hwaya Technology Park, Taoyuan County 33383, Taiwan

(Company Address)

Person responsible for this declaration:

Mr. Benjamin Huang

(Name, Surname)

Division Vice President

(Position/Title)

Taiwan

2013.05.16

(Place)

(Date)

Benjamin Huang
(Legal Signature)

Safety Summary

The following general safety precautions must be observed during all phases of operation, service, and repair of this instrument. Failure to comply with these precautions or specific WARNINGS given elsewhere in this manual will violate safety standards of design, manufacture, and intended use of the instrument. *Chroma* assumes no liability for the customer's failure to comply with these requirements.



BEFORE APPLYING POWER

Verify that the power is set to match the rated input of this power supply.



PROTECTIVE GROUNDING

Make sure to connect the protective grounding to prevent an electric shock before turning on the power.



NECESSITY OF PROTECTIVE GROUNDING

Never cut off the internal or external protective grounding wire, or disconnect the wiring of protective grounding terminal. Doing so will cause a potential shock hazard that may bring injury to a person.



FUSES

Only fuses with the required rated current, voltage, and specified type (normal blow, time delay, etc.) should be used. Do not use repaired fuses or short-circuited fuse holders. To do so could cause a shock or fire hazard.



DO NOT OPERATE IN AN EXPLOSIVE ATMOSPHERE

Do not operate the instrument in the presence of flammable gases or fumes. The instrument should be used in an environment of good ventilation.



DO NOT REMOVE THE COVER OF THE INSTRUMENT

Operating personnel must not remove the cover of the instrument. Component replacement and internal adjustment can be done only by qualified service personnel.

Safety Symbols



DANGER – High voltage.



Explanation: To avoid injury, death of personnel, or damage to the instrument, the operator must refer to an explanation in the instruction manual.



High temperature: This symbol indicates the temperature is now higher than the acceptable range of human. Do not touch it to avoid any personal injury.



Protective grounding terminal: To protect against electrical shock in case of a fault. This symbol indicates that the terminal must be connected to ground before operation of equipment.



The **WARNING** sign denotes a hazard. It calls attention to a procedure, practice, or the like, which, if not correctly performed or adhered to, could result in personal injury. Do not proceed beyond a **WARNING** sign until the indicated conditions are fully understood and met.



The **CAUTION** sign denotes a hazard. It may result in personal injury or death if not noticed timely. It calls attention to procedures, practices and conditions.



This indicates important information or tips for the procedures and applications, etc. The contents should be read carefully.

Revision History

The following lists the additions, deletions and modifications in this manual at each revision.

Date	Version	Revised Sections
Oct. 2008	1.0	Complete this manual.
Mar. 2009	1.1	Add the contents about <i>“RS-232 Communication Interface”</i> .
Jul. 2013	1.2	Add <i>“Material Contents Declaration”</i> , <i>“CE Declaration”</i> and <i>“Table 1-1 Standard Accessory”</i> . Modify the figure in the section of <i>“Ambient Environment”</i> . Modify the descriptions and figures in the section of <i>“Open Correction”</i> , <i>“Short Correction”</i> , <i>“RS-232 Interface Connector”</i> and <i>“RS-232 Signal Cable and Pin Table”</i> .

Table of Contents

1.	Introduction.....	1-1
1.1	An Overview of Product	1-1
1.2	Brief Specifications	1-1
1.3	Incoming Inspection.....	1-2
1.4	Initial Inspection	1-3
1.5	Common Environment Conditions	1-3
1.6	Maintenance & Cleaning.....	1-3
2.	Specifications (15°C~35°C, RH ≤ 75%)	2-1
2.1	Measurement Functions	2-1
2.2	Test Signals	2-1
2.3	Measurement Range	2-2
2.4	Accuracy	2-2
2.5	Zero	2-6
2.6	Measurement Time.....	2-6
2.7	Others	2-6
3.	Installation.....	3-1
3.1	Ambient Environment	3-1
3.2	Power-Line Connection	3-1
3.3	Fuse.....	3-2
3.4	Power Regulation	3-2
3.5	Connecting Unknown.....	3-2
4.	Panel Description	4-1
4.1	Front Panel	4-1
4.2	Rear Panel.....	4-3
4.3	Description of System Parameters Setting	4-5
4.3.1	System Setup.....	4-5
4.3.2	Memory Management Instruction	4-8
4.4	Operation Instruction	4-9
4.4.1	Open Correction.....	4-9
4.4.2	Short Correction.....	4-10
4.4.3	Setup of LCRZ Parameter	4-11
4.4.4	Binning SET	4-14
4.4.5	Description of Compare Setting Operation	4-17
4.4.6	Bias Compare	4-18
4.4.7	Description of Loading Correction Function.....	4-24
4.4.8	Operation of Bin Sorting 99 Groups.....	4-25
4.4.9	Dual Frequency Function (Option).....	4-27
5.	Description of GPIB/RS-232 Interface	5-1
5.1	Overview	5-1
5.2	GPIB Interface Specification.....	5-1
5.2.1	IEEE- 488 Interface Function.....	5-1
5.2.2	Using Code	5-1
5.2.3	TALK/LISTEN Function.....	5-1
5.2.4	IEEE-488 Interface Connector	5-2
5.2.5	Signal Lines of the IEEE-488 Interface Bus.....	5-2
5.2.6	Response of Interface Messages	5-3
5.2.7	Bus Driver	5-3
5.2.8	Command Error Message.....	5-3
5.3	RS-232 Interface Specification (Option)	5-3
5.3.1	Interface Specification.....	5-3

5.3.2	RS-232 Interface Connector	5-4
5.3.3	RS-232 Signal Cable and Pin Table.....	5-4
5.4	Command Description	5-5
5.4.1	Command Configuration	5-5
5.4.2	Description for Command Configuration.....	5-6
5.4.3	Command Syntax	5-7
5.4.4	Common Command.....	5-8
5.4.5	Command Description	5-9
5.4.6	Command Notices	5-22
5.4.7	Format of Data Transfer.....	5-23
5.5	Disable Connection (Remote) Mode.....	5-23
5.6	Status Reporting Structure	5-24
5.7	Status Byte Register	5-25
5.8	Standard Event Status Register	5-26
5.9	Standard Operation Status Group	5-27
6.	Description of Handler Interface	6-1
6.1	Description for Binning Handler Interface Pin.....	6-1
6.1.1	50 Pin.....	6-1
6.1.2	24 Pin.....	6-2
6.2	Description for Compare Handler Interface Pin	6-2
6.2.1	50 Pin.....	6-2
6.2.2	24 Pin.....	6-3
6.3	Description for Bias Compare Handler Interface Pin	6-4
6.3.1	50 Pin.....	6-4
6.3.2	24 Pin.....	6-4
6.4	Description for Link 1320 Handler Interface Pin	6-5
6.4.1	50 Pin.....	6-5
6.5	Description for Bin99 Groups Handler Interface Pin.....	6-5
6.6	Handler Interface Description of Dual Frequency (Option).....	6-6
6.6.1	50 Pin.....	6-6
6.6.2	24 Pin.....	6-7
6.7	Timing Relation of Handler Interface Control Signal.....	6-7
6.7.1	Setting without Trigger Delay Time (Freq. \geq 100Hz)	6-7
6.7.2	Setting with Trigger Delay Time (Freq. \geq 100Hz)	6-9
Appendix A	Optional Accessory	A-1

1. Introduction

1.1 An Overview of Product

The **11022 LCR Meter** is an automatic instrument used for testing and analyzing components. The unit was designed to solve the problems of low labor efficiency and low product quality that have occurred since the electronics sector began to flourish.

The testing functions included in this unit are: L, C, R, and Z, which supply the perfect functions on the production line and in quality control.

By using the internal microprocessor, the unit can support fast, highly accurate and reliable testing at low cost. The functions are as follows: Hi or Lo-limit comparator; testing frequency; selector of testing voltage; data store and recall; GPIB or RS-232 (option) interface controls 11022 and data transfer; and statistics analysis function from PC. The unit can send the test results to an external unit for checking the response of the component by handler interface.

The multi-functions testing device, ergonomics keyboard design, guided panel operation, extra-large LCD, and password protection makes the 11022 unit easy to operate and ensures high accuracy.

The basic accuracy is 0.1%. The measurement device (optional) can perform the calibration by keying-in the measuring parameter. The calibration procedure can be finished easily for users by offering OPEN and SHORT.

If the unit requires external or extended testing, please be aware the correct connection of four terminals. In cases of high-frequency measurement, it is necessary to consider the high-frequency response.

1.2 Brief Specifications

- **Measurement Parameter:** Primary parameters -- L, C, R and $|Z|$
: Secondary parameters– Q, D, θ , ESR and Xs
- **Basic Accuracy:** Basic 0.1% (1kHz/1V rms)
- **Measurement Range:**

L	–	.001uH	~	99.999kH
C	–	.001pF	~	1.9999F
R	–	.01m Ω	~	99.99M Ω
$ Z $	–	.01m Ω	~	99.99M Ω
Q	–	.0001	~	9999
D	–	.0001	~	9999
θ	–	-180.00°	~	+180.00°
- **Measurement Frequency:** 50Hz, 60Hz, 100Hz, 120Hz, 1kHz, 10kHz, 20kHz, 40kHz, 50kHz and 100kHz
- **Measurement Voltage** : 10mV to 1.0V rms, each step by 10mV
- **Equivalent Circuit** : Series, Parallel
- **Zeroing Calibration** : Open, Short

- **Interfaces** : GPIB, Handler and RS-232 interface

1.3 Incoming Inspection

Upon receipt of this instrument, please check the items as following:

- (1) Any damages or scratches on the surface of the product.
- (2) Listed in Table 1-1 and Table 1-2 are accessories for this instrument.

If you found any damages or discover that accessories are missing, please contact our company, branches, or agents for prompt service.

Table 1-1 Standard Accessory





Item				
Name	11022 Traditional Chinese Quick Start Guide * 1pc	11022 English Quick Start Guide * 1pc	11022 User's Manual CD*1	US Power Cord 1.83M*1pc
Item				
Name	Power Connector 3PIN to 2PIN* 1pc	AC 110V used 1A/250V Fuse *2pcs	AC 220V used 0.5A/250V Fuse *2pcs	High-frequency Test Cable*1pc

Table 1-2 Optional Accessory

Item	Qty	Description
A110211 Component Test Box	1	Test box for DIP type passive component
A110212 Component Remote Test Box	1	Remote test box (1 meter) of DIP type passive component
A110104 SMD Test Cable	1	Test cable for SMD type passive component
A110232 4 BNC Test Cable	1	4-Terminal test cable
A133004 SMD Test Box	1	Test box for SMD type passive component
50 Pin Handler Control Line	1	2-terminal 50 Pin Handler connector (M) control line (0.5 m)
50 Pin Handler Control Line	1	2-terminal 50 Pin Handler connector (M) control line (1.5 m)
24 Pin Handler Control Line	1	2-terminal 24 Pin Handler connector (M) control line (1 m)
Chroma 1320 Control Line	1	50 Pin Handler connector (M)/ 24 Pin Handler connector (M)/ 9Pin D-SUB (F) control line (2 m)
A110239 4 Terminals SMD Electrical Capacitor Test Box	1	Test box for SMD type electrical capacitor
A110236 Rack Mountain Kit	1	Fixed on system rack

A110242 Battery ESR Test Kit	1	Test box for isolating DUT DC voltage
A110244 High Capacitance Capacitor Test Fixture	1	Test cable for high capacitance electrical capacitor
A110245 Ring Core Test Fixture	1	For measuring ring core
A132574 SMD Test Box	1	Test box for SMD type Power Choke

1.4 Initial Inspection

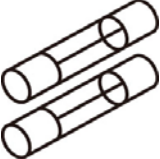
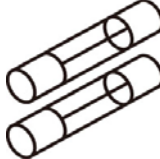
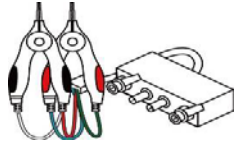
Before shipment, this instrument was inspected and found to be free of mechanical and electrical defects. As soon as the instrument is unpacked, inspect for any damage that may have occurred in transit. Save all packing materials in case that the instrument has to be returned. If damage is found, please file claim with carrier immediately. Do not return the instrument to Chroma without prior approval.

1.5 Common Environment Conditions

1. Indoor use
2. Altitude: 2000 m
3. Temperature: 5°C to 40°C
4. Humidity: Maximum 80%RH at 31°C decreasing to 50%RH at 40°C
5. Transient Overvoltage at Mains Supply: 2500V
6. Pollution Degree: 2

1.6 Maintenance & Cleaning

Remove all connected wires and cables on the instrument before cleaning. Use a brush to clean the dust on it. For internal cleaning, use a low-pressure air gun to vacuum the dust inside or send it back to the distributors or agents of Chroma for cleaning.

2. Specifications (15°C~35°C, RH ≤ 75%)

2.1 Measurement Functions

Measurement Parameters:

Primary Parameter

L	Inductance	unit: uH, mH, H, kH
C	Capacitance	unit: pF, nF, uF, mF
R	Resistance	unit: mΩ, Ω, kΩ, MΩ
Z	Absolute value of impedance	unit: mΩ, Ω, kΩ, MΩ

Secondary Parameter

Q	Quality factor	
D	Dissipation factor	
ESR	Equivalent series resistance	unit: mΩ, Ω, kΩ, MΩ
θ	Phase angle	unit: ° ; degree
Xs	Reactance	unit: mΩ, Ω, kΩ, MΩ

Equivalent Measurement Circuit: Parallel and Series

Ranging: Auto and Manual

Trigger mode: Internal, Manual and External (GPIB, Handler, RS-232 Interface).

Measurement terminals: 4-terminal.

Measurement speed: Fast, Medium and Slow.

2.2 Test Signals

Frequency:

11022 : 50Hz, 60Hz, 100Hz, 120Hz, 1kHz, 10kHz, 20kHz, 40kHz, 50kHz and 100kHz
Accuracy : ± (0.01% ± 0.01Hz)

Voltage: 10mV ~ 1.0Vrms, 10mV/step

Output Impedance:

Constant mode 25 OHM: 25Ω ±5%

Constant mode 100 OHM: 100Ω ±5%

Constant mode 10 OHM/C.C: DUT impedance ≥10Ω is 10Ω ±10%.

C.C: Constant Current Lower than 10Ω inductive load is 100mA ± 5% (When test voltage is 1V).

Constant mode 100/25 OHM: 25Ω ± 5%, DUT impedance < 1Ω.

100Ω ± 5%, DUT impedance ≥ 1Ω.

2.3 Measurement Range

Parameter	Range
L	0.001uH ~ 99.999kH
C	0.001pF ~ 1.9999F
R	0.01mΩ ~ 99.99MΩ
Z	0.01mΩ ~ 99.99MΩ
Q	0.0001 ~ 9999
D	0.0001 ~ 9999
θ	-180.00° ~ +180.00°

2.4 Accuracy

- Within 1 year of factory calibration.
- Temperature: 23°C ± 5°C
- Relative humidity: 90% maximum
- Warm up: 30 minutes minimum.
- Zero calibrated under above conditions.

1. |Z| - θ Accuracy

The basic accuracy is listed in *Table 2-1*.

- For fast rate, the accuracy must be doubled.

Z (Ω)	10M	0.6%	0.6%	0.48%	0.4%	0.35%					
		0.8°	0.8°	0.5°	0.45°	0.4°					
	1M	0.4%	0.4%	0.24%	0.20%	0.16%	0.5%	1.5%	2%	2%	2%
		0.6°	0.6°	0.33°	0.3°	0.08°	0.12°	0.12°	0.24°	0.24°	0.4°
	100k	0.3%	0.3%	0.2%	0.2%	0.12%	0.5%	1.5%	1.8%	1.8%	2%
		0.4°	0.4°	0.24°	0.24°	0.06°	0.08°	0.09°	0.24°	0.24°	0.3°
	10k	0.3%	0.3%	0.2%	0.2%	0.1%	0.45%	0.5%	0.6%	0.6%	0.7%
		0.2°	0.2°	0.2°	0.2°	0.05°	0.07°	0.08°	0.08°	0.08°	0.2°
1k	0.3%	0.3%	0.2%	0.2%	0.1%	0.2%	0.36%	0.4%	0.4%	0.45%	
	0.2°	0.2°	0.2°	0.2°	0.05°	0.07°	0.08°	0.08°	0.08°	0.2°	
100	0.4%	0.4%	0.25%	0.25%	0.24%	0.26%	0.36%	0.4%	0.4%	0.5%	
	0.2°	0.2°	0.2°	0.2°	0.09°	0.09°	0.15°	0.17°	0.17°	0.2°	
10	0.5%	0.5%	0.45%	0.4%	0.32%	0.35%	0.4%	0.5%	0.5%	0.6%	
	0.3°	0.3°	0.22°	0.22°	0.09°	0.15°	0.15°	0.17°	0.17°	0.2°	
1	0.8%	0.8%	0.7%	0.5%	0.35%	0.35%	0.4%	0.7%	0.7%	0.9%	
	0.4°	0.4°	0.24°	0.24°	0.15°	0.15°	0.2°	0.26°	0.26°	0.6°	
0.1											
		50Hz	60Hz	100Hz	120Hz	1kHz	10kHz	20kHz	40kHz	50kHz	100kHz

Frequency (Hz)
Table 2-1 |Z|, θ Accuracy

When |Z| < 0.1Ω,

$$|Z| \text{ accuracy (Ze [\%])} = A + B \times \frac{100\text{m}\Omega}{|Z|} + \frac{C}{|Z|}$$

$$\theta \text{ accuracy } (\theta e) = \frac{180^\circ}{\pi} \times Ze$$

Frequency		50Hz	60Hz	100Hz	120Hz	1kHz	10kHz	20kHz	40kHz	50kHz	100kHz
Parameter											
A		0.8	0.7	0.6	0.4	0.3	0.3	0.4	0.5	0.6	0.8
B		0.15	0.14	0.12	0.12	0.08	0.08	0.09	0.1	0.1	0.12
C (Cable length)	0M	0Ω	0Ω	0.001Ω	0.0012Ω	0.002Ω	0.02Ω	0.04Ω	0.08Ω	0.1Ω	0.2Ω
	1M	0.004Ω	0.006Ω	0.008Ω	0.009Ω	0.012Ω	0.07Ω	0.14Ω	0.28Ω	0.35Ω	0.7Ω
	2M	0.008Ω	0.010Ω	0.015Ω	0.017Ω	0.022Ω	0.12Ω	0.24Ω	0.48Ω	0.6Ω	-

Table 2-2

When the test signal level is not set to 1V, multiply the |Z| and θ accuracy by the parameter D in accordance with Vs in Table 2-3.

Level	1V > Vs > 0.5V	0.5V ≥ Vs ≥ 0.25V	0.25V > Vs ≥ 0.01V
D	1	2	$\frac{0.5V}{Vs}$

Table 2-3

Example:

The test frequency is 1kHz, voltage is 0.5V, test cable length is 1M and measuring an inductor L is 10uH and Q value is 5, the calculation of accuracy is shown below.

First is to get the impedance of inductor. $|Z| = 2\pi \times 1\text{kHz} \times 10\mu\text{H} = 0.06283\Omega < 0.1\Omega$

$$Ze = A + B \times \frac{100\text{m}\Omega}{|Z|} + \frac{C}{|Z|} = 0.3 + 0.08 \times \frac{100\text{m}\Omega}{|Z|} + \frac{0.012\Omega}{|Z|} = 0.618\%$$

When 11022 under these conditions means the inductor provided accuracy is within 0.618%.

$$\theta e = \frac{180^\circ}{\pi} \times Ze = 0.354^\circ$$

$$\Delta Q = \pm \frac{\tan \theta e \times (1 + Q^2)}{1 - Q \times \tan \theta e} = \pm 0.166$$

Because Q = 5 < 10

$$\text{So Q accuracy} = \pm 0.166 \times (1 + \frac{1}{Q}) = \pm 0.1992$$

2. L, C Accuracy

For Q ≥ 10 that is D ≤ 0.1, corresponds to accuracy of |Z|, where

$$|Z_L| = |2\pi fL|$$

$$|Z_C| = |1/(2\pi fC)|$$

Refer to conversion chart between LC and |Z| in Figure 2-1. If Q < 10 that is D > 0.1, multiply L accuracy by (1 + 1/Q) and multiply C accuracy by (1 + D).

3. D, Q Accuracy

For all D value

$$\text{Accuracy of D} = \pm \frac{\tan\theta_e \times (1 + D^2)}{1 - D \times \tan\theta_e}$$

For $Q \geq 10$

$$\text{Accuracy of Q} = \pm \frac{\tan\theta_e \times (1 + Q^2)}{1 - Q \times \tan\theta_e}$$

If $Q < 10$, multiply accuracy Q by $(1 + 1/Q)$

※ θ_e is θ error specification in *Table 2-1*.

4. ESR, EPR Accuracy

For $Q \leq 0.1$

Accuracy of R = Accuracy of $|Z|$

If $Q \geq 0.1$, multiply accuracy by $(1 + Q)$

5. About the accuracy of dual frequency function please see *4.4.9 Dual Frequency Function (Option)*.

Figure2-1 LC — $|Z|$ conversion chart

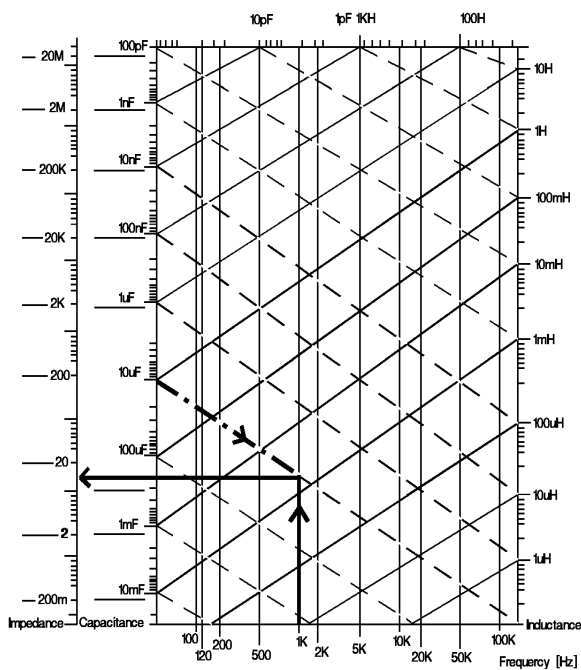
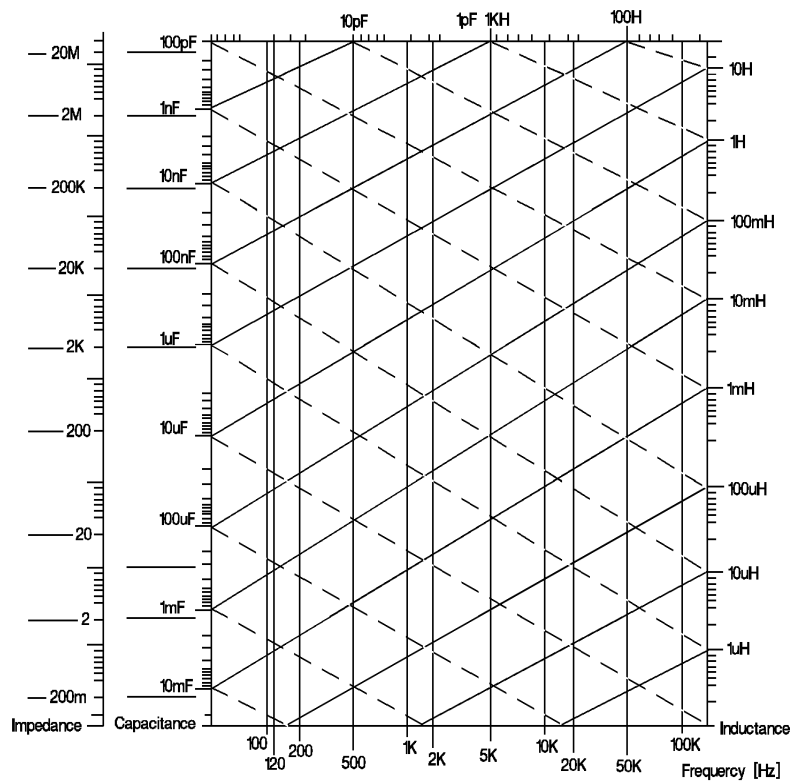

(b). $C \rightarrow |Z|$ conversion chart

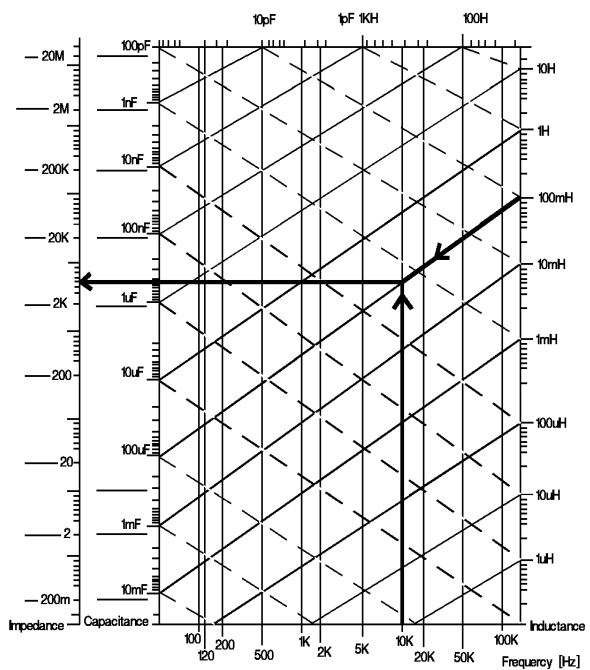

(c). $L \rightarrow |Z|$ conversion chart

2.5 Zero

Zero open:

Eliminate measurement errors due to parasitic stray impedances of the test fixture.

Zero short:

Eliminate measurement errors due to parasitic residual impedances of the test fixture.

2.6 Measurement Time

Start from measurement, analog sampling calculation to Binning or Compare signal output measuring time. Please refer to the *Table 2-4*. (INTEG. CYCLE is set "1", please refer to page 4-6)

Item	Fast	Medium	Slow
4-terminal testing	21 mS 26 mS (50, 60Hz)	51 mS	360 mS

Table 2-4 Measurement Time

About the measurement time of dual frequency function please see *4.4.9 Dual Frequency Function (Option)*.

2.7 Others

- **Power:** 90V ~ 125V AC, 50Hz/60Hz. Power consumption is 65W, maximum.
190V ~ 250V AC, 50Hz/60Hz. Power consumption is 65W, maximum.
- **Environment:** Operating -- 10°C to 40°C, 10 to 90% relative humidity.
Storage -- 0°C to 50°C, 10 to 90% relative humidity.
- **Dimensions:** 320(W) x 115(H) x 350(D)
- **Weight** : Approx. 5.4kg.

3. Installation

3.1 Ambient Environment

- (1) Do not use the meter in a dusty or vibrating location. Do not expose it to sunlight or corrosive gas. Be sure that the ambient temperature is 10 ~ 40°C and that the relative humidity is below 90%.
- (2) The rear of the meter is equipped with a cooling fan to keep the internal temperature rising, so adequate ventilation should be ensured. The meter should be located at least 10cm from any object or wall behind it. Do not block the left and right ventilation holes to keep the meter in good precision.
- (3) The meter has been carefully designed to reduce the noise from the AC power source. However, it should be used in a noise environment as low as possible. If noise is inevitable, please install a power filter.
- (4) The meter should be stored within the temperature range 0°C ~ 50°C. If the unit is not to be in use for a long time, please store it in the original or similar package and keep it from direct sunlight and humidity.

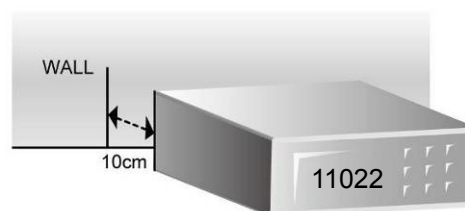
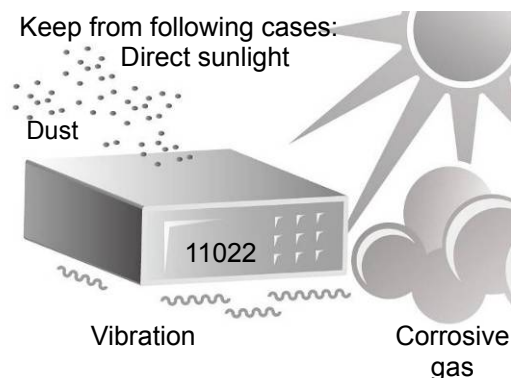

Keep from objects in the behind at over 10cm

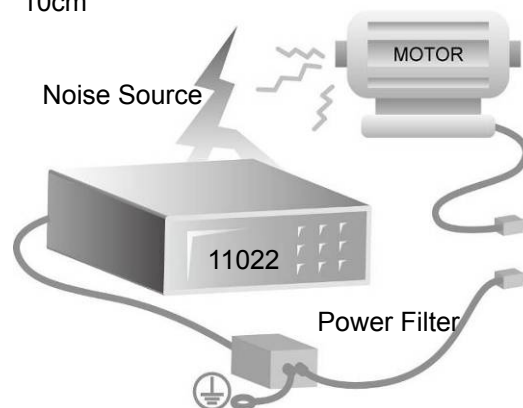

Please install the power filter in case of interface from high power

3.2 Power-Line Connection

Before plugging in the power cord, make sure the power switch is in the off position and that the voltage of the rear panel meets the required voltage. Please use the 50 Hz or 60Hz power supply frequency.

3.3 Fuse

There is one fuse installed in the rear panel. When replacing the fuse, please turn off the power and pull the plug from the power supply.

Fuse spec. AC 100V ~ 120V → T1.0A 250V
AC 220V ~ 240V → T0.5A 250V

For reasons of safety and noise reduction, use a power cord corresponding to the illustration in below figure:

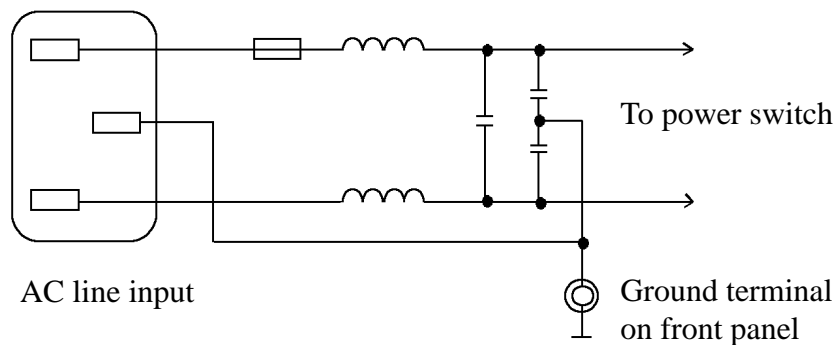

3.4 Power Regulation

As this instrument is a precision electronic test device, so the accuracy is possible to be influenced lower by input power unstable after testing. There is $\pm 10\%$ changeable power even in the laboratory, so we suggest that use the regulator in power and test devices the only one way to avoid the reasons that cause by power unstable.

3.5 Connecting Unknown

Due to the 11022 LCR METER connects to D.U.T (Unknown device), that can through the 4 BNC connectors which are Hcur, Hpot, Lpot and Lcur. Notice the Lcur and Lpot connect to DUT should be at the same terminal, Hcur and Hpot connect to another terminal.

4. Panel Description

4.1 Front Panel

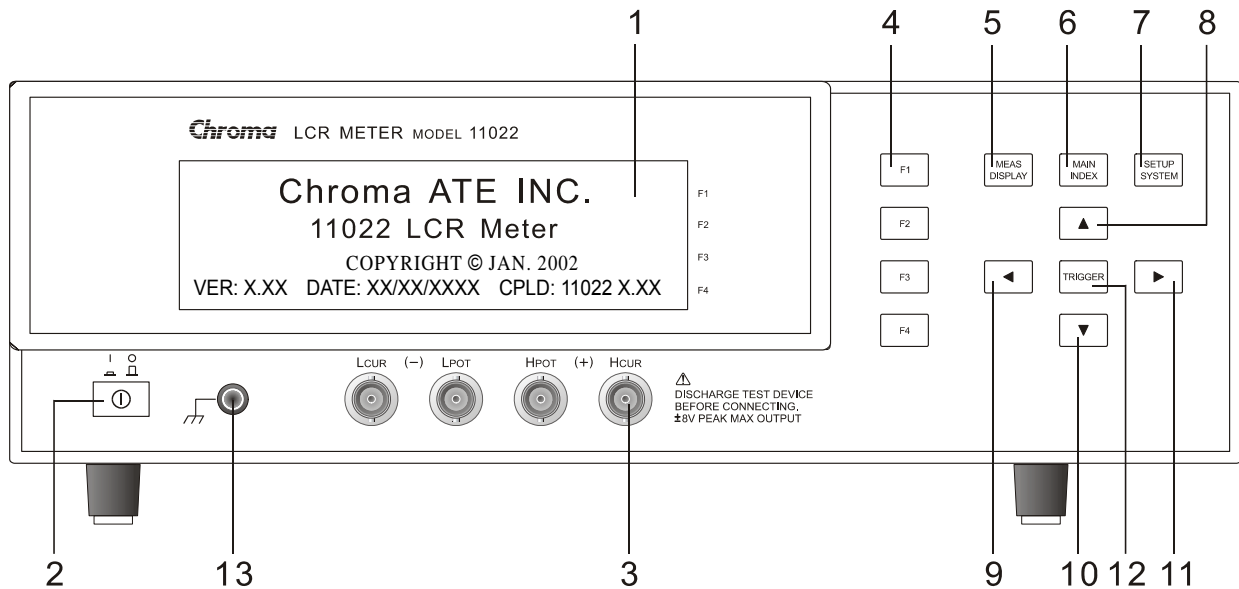

(1) LCD Display

The resolution of this instrument display is 64x240 Graphic mode LCD, so all the measurements and setting values can be shown clearly.

(2) POWER switch

On-off switch

(3) Unknown measurement connectors

Four individual BNC sockets connect an external test device or wire for unknown testing.

H_{Cur} : High terminal of current drive.
 H_{pot} : High terminal of potential detector.
 L_{pot} : Low terminal of potential detector.
 L_{Cur} : Low terminal of current drive.

⚡ CAUTION : The "high" terminals for (+) and "low" terminals for (-) polarity are as marked on the front panel, while the polarized component is under test.

⚠ WARNING : To avoid shocking the instrument, please discharge the unit before measuring the pole components.

(4) Function keys

The major function of these keys is to show the different conditions of each function or other options which may need to be selected depending on the user's requirements.

(5) Measure display key

Upon pressing this key, the instrument is in basic component measurement & analysis mode. Under this screen, each test parameter can be changed directly and the value

read. For example, test voltage, parameter, speed, series or parallel...etc.

(6) Main index key

Pressing this key allows entry to the main index screen. In this screen you may select what you want to test, for example, the analysis of unknown test result, open test, short test, compare function...etc.

(7) System setup key

Pressing this key gives access to the main system parameters setup, allowing each system parameter to be changed directly, e.g., the calibration of this instrument, memory management, selection and setting parameter of each system and measurement parameter (The functions of calibration and memory-management require a password for entry).

(8) ~ (11) Cursor keys

There are four keys, corresponding to up, down, left and right. These keys are for display in different conditions and control cursor, which can be useful when inputting each parameter. The keys can also be selective, e.g., for changing values such as setting frequency or voltage.

(12) Trigger key

When starting to test the unknown, press this key when the measure condition of the instrument is a manual trigger.

(13) Ground Terminal

This terminal connects the cover of the instrument directly to ground to avoid exterior obstruction that makes connection incomplete and compromises the instrument's safety.

4.2 Rear Panel

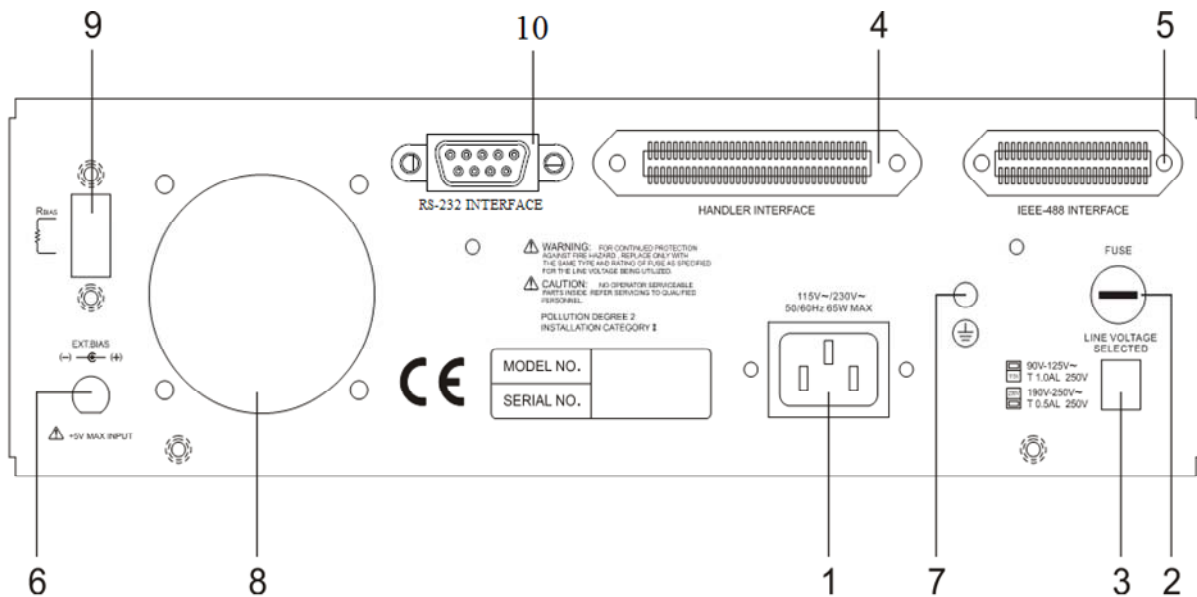

(1) AC Line Socket

This socket is an approved (by the International Electrotechnical Commission) three-line socket 320. Please use the correct wire, such as Belden SPH-386 or similar (W12 010130).

(2) Fuse

1.0A or 0.5A slow flow fuse to prevent the instrument being affected by excess current in 90 ~ 125V or 190 ~ 250V.

(3) Power Voltage Switch

Ensure power is off, then use screwdriver to switch to required voltage.

(4) HANDLER INTERFACE Socket

To component controller, output is GO/NG and status etc., input is "Start" signal. Receive Amphenol "Microribbon" plug P/N 57-30240 or equal object.

(5) IEEE-488 INTERFACE Socket

According to IEEE488-1978 standard input/output cord. The functions are: Total remote control; output selection result, with or without controller; receive IEEE-488 interface connection cord.

(6) Addition Bias

External bias can connect to test system through rear panel BIAS INPUT BNC terminal. External bias should correspond to the following specifications:

- Be sure voltage is not over 5V.
- Suggested voltage limit should be set on 1A
- Use of a good filter voltage is suggested. Because of bias, miscellaneous signal will influence test frequency and power frequency especially.
- External circuit should include any DUT bias application of switching test device and charge needs to be off before removal.
- Connect external bias and switch circuit using W38 001270 through EXT. The BIAS terminal is on the rear panel. Please pay attention to the polarity indicators on the

- panel.
- Notice the marked polarity on the panel.

(7) Guard Terminal

This terminal connects the cover of the instrument directly, then connect to the ground to avoid exterior obstruction that makes instrument connection incomplete and can compromise safety.

(8) Fan

Heat dissipation fan keeps test instrument from overheating to ensure the most accurate measurement.

(9) DC Bias Current Source

The Bias can control DC output current of measuring terminals, also relate to the setting of constant mode. Please refer to *Table 4-1*.

Constant Mode	Output R (Range)	Output current of measured terminal (A)	I _{DC} (R _{DC} < 100mΩ)	Maximum output current
25 OHM	25 Ω	$(5V \times \frac{1k\Omega}{1k\Omega+R_{BIAS}})/(25+R_{DC})$	$\frac{1k\Omega}{1k\Omega+R_{BIAS}} \times 200mA$	200 mA
100 OHM	100 Ω	$(5V \times \frac{1k\Omega}{1k\Omega+R_{BIAS}})/(100+R_{DC})$	$\frac{1k\Omega}{1k\Omega+R_{BIAS}} \times 50mA$	50 mA
100/25 OHM	100 Ω	$(5V \times \frac{1k\Omega}{1k\Omega+R_{BIAS}})/(100+R_{DC})$	$\frac{1k\Omega}{1k\Omega+R_{BIAS}} \times 50mA$	50 mA
	25 Ω	$(5V \times \frac{1k\Omega}{1k\Omega+R_{BIAS}})/(25+R_{DC})$	$\frac{1k\Omega}{1k\Omega+R_{BIAS}} \times 200mA$	200 mA
10 OHM/C.C	Function Invalid			

Table 4-1

R_{DC} : Resistance of object (Ω).

R_{BIAS} : It can gain the maximum output current, when connect external bias current source to short circuit (0Ω).

Ex.: When Constant Mode is 100/25 OHM, measure 1mH inductor by frequency 100kHz/0.1V plus DC Bias 8mA. From $Z = 2\pi fL = 628\Omega > 1\Omega$ to compare *Table 4-1* can know the max. output current is 50mA. If R_{DC}<100mΩ of this conductor, thus can get R_{BIAS} = 5.25kΩ from $\frac{1k\Omega}{1k\Omega+R_{BIAS}} \times 50mA = 8mA$.

The relative values of R_{BIAS} and V_{DC} are as Table 4-2 shows.

Constant Mode	Output R (Range)	Output voltage of measured terminal V_{DC} (V)	V_{DC} ($R_{DC} > R_O$)	Maximum output voltage V_{DC}
25 OHM	25 Ω	$(\frac{1k\Omega}{1k\Omega+R_{BIAS}} \times 5V) \times \frac{R_{DC}}{25\Omega+R_{DC}}$	$\frac{1k\Omega}{1k\Omega+R_{BIAS}} \times 5V$	5V
100 OHM	100 Ω	$(\frac{1k\Omega}{1k\Omega+R_{BIAS}} \times 5V) \times \frac{R_{DC}}{100\Omega+R_{DC}}$		
100/25 OHM	100 Ω ($Z \geq 1\Omega$)	$(\frac{1k\Omega}{1k\Omega+R_{BIAS}} \times 5V) \times \frac{R_{DC}}{100\Omega+R_{DC}}$		
	25 Ω ($Z < 1\Omega$)	$(\frac{1k\Omega}{1k\Omega+R_{BIAS}} \times 5V) \times \frac{R_{DC}}{25\Omega+R_{DC}}$	---	---
10 OHM/C.C	Function Invalid			

Table 4-2

(10)RS-232 Interface (option)

The socket is for connecting RS-232 interface. The interface of GPIB and RS-232 can't be used simultaneously.

4.3 Description of System Parameters Setting

4.3.1 System Setup

- The display shows Chroma's name, model number and programming version after the main power is switched on.

<p>Chroma ATE INC. 11022 LCR Meter COPYRIGHT © JAN. 2002 VER: X.XX DATE: XX/XX/XXXX CPLD: 11022 X.XX</p>

Remark: If you want to show this screen at any time, press [System Setup] and [\blacktriangleleft] key in sequence.

- Power on self-test screen will display for one second, after that, then enter the following screen:

< MEAS. DISPLAY >	FREQ.: 1.0 KHz	[F1] ← Test frequency setting
	LEVEL: 1.00 V	[F2] ← Test voltage setting
Cp : 0.9999 nF	PARA.: Cp - D	[F3] ← Test parameter setting
D : 0.0001	NEXT PAGE 1/4	[F4] ← To next page

- When setting test instrument system parameter setting, press [System Setup] key after power on, then enter the following screen:

< SYSTEM SETUP >	CALIBRATION
	MEM MANAGE
	SYSTEM CONFIG

- F1 ← To start the system calibration
- F2 ← To start the memory management
- F3 ← To start the system parameter setting screen
- F4

4. Press [F3] (System Configuration) key to enter system parameter setting screen as follows:

<SYSTEM CONFIG>	ON
VM/IM DISPLAY : OFF	
CONST RSOURCE : 100/25 OHM	OFF
AVERAGE TIME : 001	
CABLE LENGTH : 0M	
BEEPER : LOW	
KEY LOCK : OFF	

- F1 ← Enable
- F2 ← Disable
- F3
- F4

5. System setting screen contains four pages. Press up, down key to move cursor to another page. The second page has the following content.

<SYSTEM CONFIG>	ON
INTEG.CYCLE : 04	
CONTRAST : 07	OFF
SOUND MODE : FAIL	
ALARM MODE : PULSE	
HANDLER MODE: CLEAR	
BIN NO>9: OFF	

- F1 ← Enable
- F2 ← Disable
- F3
- F4

The third page is given below.

<SYSTEM CONFIG>	DIGIT UP
GPIB EOS CODE : 0Ah	
GPIB ADDRESS : 17	
TRIGGER DELAY : 0000 mS	DIGIT DOWN
TRIGGER EDGE : FALLING	
LINK 1320 : OFF	DIGIT
HARM CHECK : OFF	

- F1 ← The digit which cursor on for adjusting upward.
- F2 ← The digit which cursor on for adjusting downward.
- F3 ← Move the cursor to right for one digit.
- F4

The fourth page is given below.

<SYSTEM CONFIG>	SLAVE
BIAS C. MODE: SLAVE	
TEST FAIL : CONTINUE	MASTER
BAUDRATE : NONE	

- F1 ← Slave device
- F2 ← Master device
- F3
- F4

6. System parameter setting descriptions are as the following:

VM/IM DISPLAY:

Selecting Measure Display test to display or hide output voltage and current read value. The factory default value is set as "OFF."

CONST RSOURCE:

The output resistance mode on test terminal includes 25Ω, 100Ω, 10Ω/CC and 100Ω/25Ω under measurement status. The factory default value is "100Ω/25Ω".

Note  C.C: Constant Current

AVERAGE TIME:

Average time selection range is 1 ~ 256. The factory default value is set as "1."

CABLE LENGTH:

There are 4 kinds of cable length available 0M, 1M, 2M, and 4M. Default is 0M.



CAUTION  After changing the cable length please run the open/short calibration to get a more accurate results.

BEEPER:

Default value is set as "LOW". The beeper has three levels as OFF, LOW, and HIGH.

KEY LOCK:

When key lock mode is ON, only the TRIGGER key can be used. To turn off the key lock, press [F1] + [F4] + [SYSTEM SETUP].

INTEG. CYCLE:

This function is to calculate the periodic sampling. When the samplings are less, then the speed becomes fast but its stability is falling down. Therefore, when the samplings are getting more, then the speed becomes slowly, also its stability is rising up. The measurement range between 01 and 08. The factory default value is set as "04".

CONTRAST:

LCD contrast adjustment range is 0 ~ 13. The factory default value is set as "7."

SOUND MODE:

To select whether the buzzer sounds for good (PASS) or not good (FAIL) under high or low limit judgment on MEAS. DISPLAY of LCR testing. The default value is set for "FAIL."

ALARM MODE:

To select whether the alarm sounds for "SHOT" or "LEVEL" under "PULSE" or "CONTINUOUS" judgment on MEAS. DISPLAY of the LCR testing. The default value is set for "PULSE."

HANDLER MODE:

CLEAR, HOLD two modes, the factory default value is being set on CLEAR.

CLEAR: When using handler interface, each time before measurement the last test result will clear (Pass or Fail).

HOLD: When using handler interface, test result (Pass or Fail) will remain until next test result is displayed.

BIN NO>9:

Select BIN setting more than 9 groups. The factory default value is OFF.

GPIB EOS CODE:

The GPIB interface data output ending codes are set to "0Dh", "0Ah" and "0Dh + 0Ah" three modes. The factory default value is being set on "0Ah".

GPIB ADDRESS:

Select GPIB interface position. The factory default value is set as "17", with a range of 00 ~ 30.

TRIGGER DELAY:

When using with auto machinery, external trigger EXT timing will need to be adjusted because measuring speed and auto machinery ON speed must match. To adjust, TRIG, DELAY time and control range is "0000 ~ 9999" ms.

TRIGGER EDG:

The trigger mode selections are FALLING/RISING. The factory default value is set as "FALLING".

LINK 1320:

When the test instrument is linked with 1320 Bias Current Source 0-10A or 1320 Bias Current Source 0-20A, the setting value should be "ON", the preset value should be "OFF". If DUT is $L_x > 10\text{mH}$, the test instrument needs to do open circuit zeroing. When handler interface has 24Pin, this function is disabled.

HARM CHECK:

When power harmonic interference in test terminal environment can't be inevitable thus full measured signal may cause the meter abnormally. This function should be enabled at this time. The factory default value is OFF.

TEST FAIL

Whether performs the 2nd measurement when the 1st result is fail under Master Mode in Bias Compare measurement. If it sets to CONTINUE, it needs to perform the 2nd test for whatever the 1st test result is. If it sets to STOP, thus it stops to perform the 2nd test while the 1st test result is fail. The factory default value is CONTINUE.

BAUDRATE

If the function of RS-232 interface isn't purchased when buy the meter, the setting displays as NONE that can't set transmission rate. If the function of RS-232 interface is purchased, it can set transmission rate that consists of 57600bps, 38400bps, 28800bps, 19200bps and 9600bps for selection. The factory default value is 19200bps.

4.3.2 Memory Management Instruction

At SYSTEM SETUP status, press [F2] key to enter < MEMORY MANAGEMENT > menu as following:

< SYSTEM SETUP > PLEASE ENTER PASSWORD...	CALIBRATION
	MEM MANAGE
	SYSTEM CONFIG

- ← Press this key to enter system calibration screen
- ← Press this key to enter memory management
- ← Press this key to enter system configuration screen
-

Enter correct password before entering memory management instructions.

4.4 Operation Instruction

4.4.1 Open Correction

1. After turning the instrument on and ensuring every event is OK, press [Main Index] to enter main index as following.

<table style="width: 100%; border-collapse: collapse;"> <tr> <td style="width: 30%; padding: 2px;">< MAIN INDEX ></td> <td style="border-bottom: 1px solid black; padding: 2px;">BINNING</td> </tr> <tr> <td></td> <td style="border-bottom: 1px solid black; padding: 2px;">COMPARE</td> </tr> <tr> <td></td> <td style="border-bottom: 1px solid black; padding: 2px;">CORRECTION</td> </tr> <tr> <td></td> <td style="padding: 2px;">NEXT PAGE 1/2</td> </tr> </table>	< MAIN INDEX >	BINNING		COMPARE		CORRECTION		NEXT PAGE 1/2	<table style="width: 100%;"> <tr> <td style="border: 1px solid black; padding: 2px; width: 20px; text-align: center;">F1</td> <td style="padding: 2px;">← Binning setting</td> </tr> <tr> <td style="border: 1px solid black; padding: 2px; width: 20px; text-align: center;">F2</td> <td style="padding: 2px;">← Compare setting</td> </tr> <tr> <td style="border: 1px solid black; padding: 2px; width: 20px; text-align: center;">F3</td> <td style="padding: 2px;">← Zeroing correction.</td> </tr> <tr> <td style="border: 1px solid black; padding: 2px; width: 20px; text-align: center;">F4</td> <td style="padding: 2px;">← To the second page</td> </tr> </table>	F1	← Binning setting	F2	← Compare setting	F3	← Zeroing correction.	F4	← To the second page
< MAIN INDEX >	BINNING																
	COMPARE																
	CORRECTION																
	NEXT PAGE 1/2																
F1	← Binning setting																
F2	← Compare setting																
F3	← Zeroing correction.																
F4	← To the second page																

2. When [F3] key is pressed, the following screen will be displayed.

<table style="width: 100%; border-collapse: collapse;"> <tr> <td style="width: 30%; padding: 2px;">< MAIN INDEX-CORRECT ></td> <td style="border-bottom: 1px solid black; padding: 2px;"></td> </tr> <tr> <td></td> <td style="border-bottom: 1px solid black; padding: 2px;">OPEN</td> </tr> <tr> <td></td> <td style="border-bottom: 1px solid black; padding: 2px;">SHORT</td> </tr> <tr> <td></td> <td style="padding: 2px;">LOAD</td> </tr> </table>	< MAIN INDEX-CORRECT >			OPEN		SHORT		LOAD	<table style="width: 100%;"> <tr> <td style="border: 1px solid black; padding: 2px; width: 20px; text-align: center;">F1</td> <td style="padding: 2px;"></td> </tr> <tr> <td style="border: 1px solid black; padding: 2px; width: 20px; text-align: center;">F2</td> <td style="padding: 2px;">← Open correction</td> </tr> <tr> <td style="border: 1px solid black; padding: 2px; width: 20px; text-align: center;">F3</td> <td style="padding: 2px;">← Short correction</td> </tr> <tr> <td style="border: 1px solid black; padding: 2px; width: 20px; text-align: center;">F4</td> <td style="padding: 2px;">← Load correction setting</td> </tr> </table>	F1		F2	← Open correction	F3	← Short correction	F4	← Load correction setting
< MAIN INDEX-CORRECT >																	
	OPEN																
	SHORT																
	LOAD																
F1																	
F2	← Open correction																
F3	← Short correction																
F4	← Load correction setting																

3. When [F2] key is pressed, the following screen will be displayed.

<table style="width: 100%; border-collapse: collapse;"> <tr> <td style="width: 30%; padding: 2px;">< MAIN INDEX-CORRECT OPEN ></td> <td style="border-bottom: 1px solid black; padding: 2px;">SINGLE</td> </tr> <tr> <td></td> <td style="border-bottom: 1px solid black; padding: 2px;">MULTI</td> </tr> <tr> <td></td> <td style="padding: 2px;">ABORT</td> </tr> </table>	< MAIN INDEX-CORRECT OPEN >	SINGLE		MULTI		ABORT	<table style="width: 100%;"> <tr> <td style="border: 1px solid black; padding: 2px; width: 20px; text-align: center;">F1</td> <td style="padding: 2px;">← Single frequency.</td> </tr> <tr> <td style="border: 1px solid black; padding: 2px; width: 20px; text-align: center;">F2</td> <td style="padding: 2px;">← Multi frequency</td> </tr> <tr> <td style="border: 1px solid black; padding: 2px; width: 20px; text-align: center;">F3</td> <td style="padding: 2px;"></td> </tr> <tr> <td style="border: 1px solid black; padding: 2px; width: 20px; text-align: center;">F4</td> <td style="padding: 2px;">← Abort</td> </tr> </table>	F1	← Single frequency.	F2	← Multi frequency	F3		F4	← Abort
< MAIN INDEX-CORRECT OPEN >	SINGLE														
	MULTI														
	ABORT														
F1	← Single frequency.														
F2	← Multi frequency														
F3															
F4	← Abort														

4. According to requirements, select single or multi frequency will show the following screen.

<table style="width: 100%; border-collapse: collapse;"> <tr> <td style="width: 30%; padding: 2px;">< MAIN INDEX-CORRECT OPEN ></td> <td style="border-bottom: 1px solid black; padding: 2px;">SINGLE</td> </tr> <tr> <td style="padding: 2px;">OPEN CIRCUIT TEST LEADS THEN PRESS TRIGGER.</td> <td style="border-bottom: 1px solid black; padding: 2px;">MULTI</td> </tr> <tr> <td></td> <td style="padding: 2px;">ABORT</td> </tr> </table>	< MAIN INDEX-CORRECT OPEN >	SINGLE	OPEN CIRCUIT TEST LEADS THEN PRESS TRIGGER.	MULTI		ABORT	<table style="width: 100%;"> <tr> <td style="border: 1px solid black; padding: 2px; width: 20px; text-align: center;">F1</td> <td style="padding: 2px;">← Single frequency</td> </tr> <tr> <td style="border: 1px solid black; padding: 2px; width: 20px; text-align: center;">F2</td> <td style="padding: 2px;">← Multi frequency</td> </tr> <tr> <td style="border: 1px solid black; padding: 2px; width: 20px; text-align: center;">F3</td> <td style="padding: 2px;"></td> </tr> <tr> <td style="border: 1px solid black; padding: 2px; width: 20px; text-align: center;">F4</td> <td style="padding: 2px;">← Abort</td> </tr> </table>	F1	← Single frequency	F2	← Multi frequency	F3		F4	← Abort
< MAIN INDEX-CORRECT OPEN >	SINGLE														
OPEN CIRCUIT TEST LEADS THEN PRESS TRIGGER.	MULTI														
	ABORT														
F1	← Single frequency														
F2	← Multi frequency														
F3															
F4	← Abort														

Prepare the test cable and press **TRIGGER** to start the test, the figure above informs the user to process open test of test cable. Use four-end test cable attached in the instrument, the test clip will be open-circuited as the below figure shows.

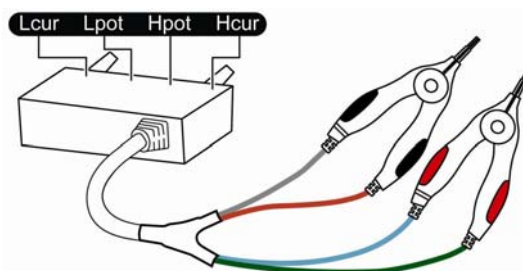

If there is anything wrong, the screen will show [FAIL], which means the procedure of open correction is wrong. Check for breaks in the test cable, ensure clips are making good contact and run test again. When open correction is successful, the screen will show

[PASS]. Press any key to escape to another index as following.

<p><MAIN INDEX-CORRECT OPEN> FREQ: 100KHz RANGE: 4 CALIB: 2 Cp: 0.000pF MEASURE PASS... 100% PRESS ANY KEY TO ESCAPE</p>	<table style="width: 100%; border-collapse: collapse;"> <tr><td style="border-bottom: 1px solid black; text-align: right; padding-right: 10px;">SINGLE</td></tr> <tr><td style="border-bottom: 1px solid black; text-align: right; padding-right: 10px;">MULTI</td></tr> <tr><td style="border-bottom: 1px solid black; text-align: right; padding-right: 10px;">ABORT</td></tr> </table>	SINGLE	MULTI	ABORT	<p>F1 ← Single frequency</p> <p>F2 ← Multi frequency</p> <p>F3</p> <p>F4 ← Abort</p>
SINGLE					
MULTI					
ABORT					

If delay time has been set in system parameter TRIGGER DELAY then the action of delay measurement will be done before starting open calibration in each test frequency.

4.4.2 Short Correction

- After turning the instrument on and ensuring every event is OK, press [Main Index] to enter main index, as the following.

<p>< MAIN INDEX ></p>	<table style="width: 100%; border-collapse: collapse;"> <tr><td style="border-bottom: 1px solid black; text-align: right; padding-right: 10px;">BINNING</td></tr> <tr><td style="border-bottom: 1px solid black; text-align: right; padding-right: 10px;">COMPARE</td></tr> <tr><td style="border-bottom: 1px solid black; text-align: right; padding-right: 10px;">CORRECTION</td></tr> <tr><td style="border-bottom: 1px solid black; text-align: right; padding-right: 10px;">NEXT PAGE 1/2</td></tr> </table>	BINNING	COMPARE	CORRECTION	NEXT PAGE 1/2	<p>F1 ← Binning setting</p> <p>F2 ← Compare setting</p> <p>F3 ← Zero correction</p> <p>F4 ← To next page</p>
BINNING						
COMPARE						
CORRECTION						
NEXT PAGE 1/2						

- Pressing [F3] key will display the following screen.

<p>< MAIN INDEX-CORRECT ></p>	<table style="width: 100%; border-collapse: collapse;"> <tr><td style="border-bottom: 1px solid black; text-align: right; padding-right: 10px;">OPEN</td></tr> <tr><td style="border-bottom: 1px solid black; text-align: right; padding-right: 10px;">SHORT</td></tr> <tr><td style="border-bottom: 1px solid black; text-align: right; padding-right: 10px;">LOAD</td></tr> </table>	OPEN	SHORT	LOAD	<p>F1</p> <p>F2 ← Open correction</p> <p>F3 ← Short correction</p> <p>F4 ← Load correction setting</p>
OPEN					
SHORT					
LOAD					

- Pressing [F3] key will display the following screen:

<p><MAIN INDEX-CORRECT SHORT></p>	<table style="width: 100%; border-collapse: collapse;"> <tr><td style="border-bottom: 1px solid black; text-align: right; padding-right: 10px;">SINGLE</td></tr> <tr><td style="border-bottom: 1px solid black; text-align: right; padding-right: 10px;">MULTI</td></tr> <tr><td style="border-bottom: 1px solid black; text-align: right; padding-right: 10px;">ABORT</td></tr> </table>	SINGLE	MULTI	ABORT	<p>F1 ← Single frequency</p> <p>F2 ← Multi frequency</p> <p>F3</p> <p>F4 ← Abort</p>
SINGLE					
MULTI					
ABORT					

- According to requirement selecting Single or Multi frequency will show the following screen.

<p><MAIN INDEX-CORRECT SHORT> SHORT CIRCUIT TEST LEADS THEN PRESS TRIGGER.</p>	<table style="width: 100%; border-collapse: collapse;"> <tr><td style="border-bottom: 1px solid black; text-align: right; padding-right: 10px;">SINGLE</td></tr> <tr><td style="border-bottom: 1px solid black; text-align: right; padding-right: 10px;">MULTI</td></tr> <tr><td style="border-bottom: 1px solid black; text-align: right; padding-right: 10px;">ABORT</td></tr> </table>	SINGLE	MULTI	ABORT	<p>F1 ← Single frequency</p> <p>F2 ← Multi frequency</p> <p>F3</p> <p>F4 ← Abort</p>
SINGLE					
MULTI					
ABORT					

Prepare the test cable and press **TRIGGER** to start the test, the figure above informs the user to process short test of test cable. Use four-end test cable attached in the instrument, the test clip will be short-circuited as the below figure shows.

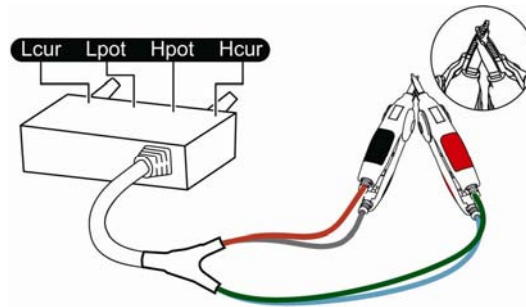

The test cable is connected as the above figure shows, connect H_{CUR} to L_{CUR} and P_{POT} to C_{CUR}. Press Trig key to process short test. The display shows FAIL as short test error, it indicates short test action with problem. Check if the test cable is broken or the clip with bad contact, re-execute short test after inspecting.

When short correction is successful, the display shows [PASS]. Press any key to escape to another index as the following:

<MAIN INDEX-CORRECT SHORT>		SINGLE	F1 ← Single frequency
FREQ: 100KHz	RANGE: 12	MULTI	F2 ← Multi frequency
	CALIB: 3		F3
R_s: 0.00mΩ			F4 ← Abort
MEASURED PASS... 100%			
PRESS ANY KEY TO ESCAPE	ABORT		

If delay time has been set in system parameter TRIGGER DELAY then the action of delay measurement will be done before starting short calibration in each test frequency.

4.4.3 Setup of LCRZ Parameter

1. Turn the power on, ensure the instrument shows everything is OK and press [Measure Display] to enter the LCRZ component parameter test as follows:

< MEAS. DISPLAY >		FREQ. : 1.0 KHz	F1 ← Test frequency setting.
Cp : 0.02 pF		LEVEL : 1.00 V	F2 ← Test voltage setting
D : 0.0001		RARA. : Cp - D	F3 ← Test parameter setting
		NEXT PAGE 1/4	F4 ← Enter the second page

< MEAS. DISPLAY >		RANGE : A 1.0MΩ	F1 ← Range setting.
Cp : 0.02 pF		SPEED : MEDIUM	F2 ← Test speed setting
D : 0.0001		TRIG. : INT	F3 ← Trigger mode setting.
		NEXT PAGE 2/4	F4 ← Enter the third page

< MEAS. DISPLAY >		BIAS V : OFF	F1 ← External DCV setting
Cp : 0.02 pF		BINNING : OFF	F2 ← Binning setting.
D : 0.0001		COMPARE : OFF	F3 ← Compare setting.
		NEXT PAGE 3/4	F4 ← Enter to the fourth page

< MEAS. DISPLAY > Cp : 0.02 pF D : 0.0001	BIAS I : OFF	F1	← Control bias source ON/OFF
	BIAS I 000.000A	F2	← Control bias source value setting
		F3	
	NEXT PAGE 4/4	F4	← Enter to the first page

2. The parameter setting descriptions are as the following:

FREQ: Test frequency setting. There are ten frequencies – 50Hz, 60Hz, 100Hz, 120Hz, 1kHz, 10kHz, 20kHz, 40kHz, 50kHz, and 100kHz. The default value is set as “1kHz.” To setup frequency, press [F1] and when frequency item is highlighted, press up or down key to select frequency.

LEVEL: Test voltage setting. The range is 0.01 ~ 1.00 Vrms. The factory value is set as “1.00V.” The set voltage, press [F2] and when voltage item is highlighted, press up or down key to select voltage.

PARA: Test parameter setting. The parameter has three parts. The first is primary parameter with L, C, R, and Z. The second is Series, Parallel modes. The third is secondary parameter with Q, D, ESR, θ and Xs. Selecting these parts, press [F3] or left, right key. Move highlight cursor to select, then press up, down key to select parameter.

RANGE: Range setting. A means Auto, H means Hold. Press [F1] to highlight this item, then press the bottom to moving Switch using up or down key. The files are 1M Ω , 300k Ω , 100k Ω , 30k Ω , 10k Ω , 3k Ω , 1k Ω , 300 Ω , 100 Ω , 10 Ω , 1 Ω , and 100m Ω (It doesn't has 300k Ω , 30k Ω , 3k Ω , 300 Ω when the test frequency at 100Hz and 120Hz.). Setting method is the same as previous item.

SPEED: Measuring speed setting. FAST measuring speed is 15ms, MEDIUM measuring speed is 45ms, SLOW measuring speed is 300ms. The lower the speed, the more stable is the measuring stability. To set, press [F2] to select and press [F2] again to change measuring speed. The factory default value is set as “MEDIUM.”

TRIG: Trigger mode. There are three modes – Internal, External and Manual. Switch by pressing [F3]. Factory default value is set as “INTERNAL.”

BIAS V: External Bias setting. Press [F1] to switch OFF/ON. For further details, refer to rear panel descriptions.

BINNING: Binning setting. Press [F2] to switch OFF/ON. If setting is “ON” it will show BIN X under measuring screen. Setting parameter is under Main Index screen.

COMPARE: Compare setting. Measuring judgment or not setting. There are four kinds – OFF, ON-VAL, ON- Δ and ON- $\Delta\%$. Press [F3] to switch. Setting parameter is under Main Index screen.

BIAS I: It is the function for connecting 1320 Bias Current Source 0-10A or 1320 Bias

Current Source 0-20A. You can press [F1] to change OFF/ON on the premise that LINK 1320 function in system setting parameter should be turned on. Please see 4.3.1 System Setup. BIAS I function can be used only when make a connection of 50 Pin Handler interface and 1320 Bias Current Source 0-10A or 1320 Bias Current Source 0-20A by using Chroma 1320 control line in Table 1-2 Optional Accessory. The connection is shown as below. To avoid control signal interferes each other, please be careful that 24 Pin Handler connector (M) and 9 Pin D-SUB connector (F) of Chroma 1320 control line can't be connected simultaneously. Meanwhile, 9 Pin D-SUB(F) should be connected and power off the two units and then perform connection.

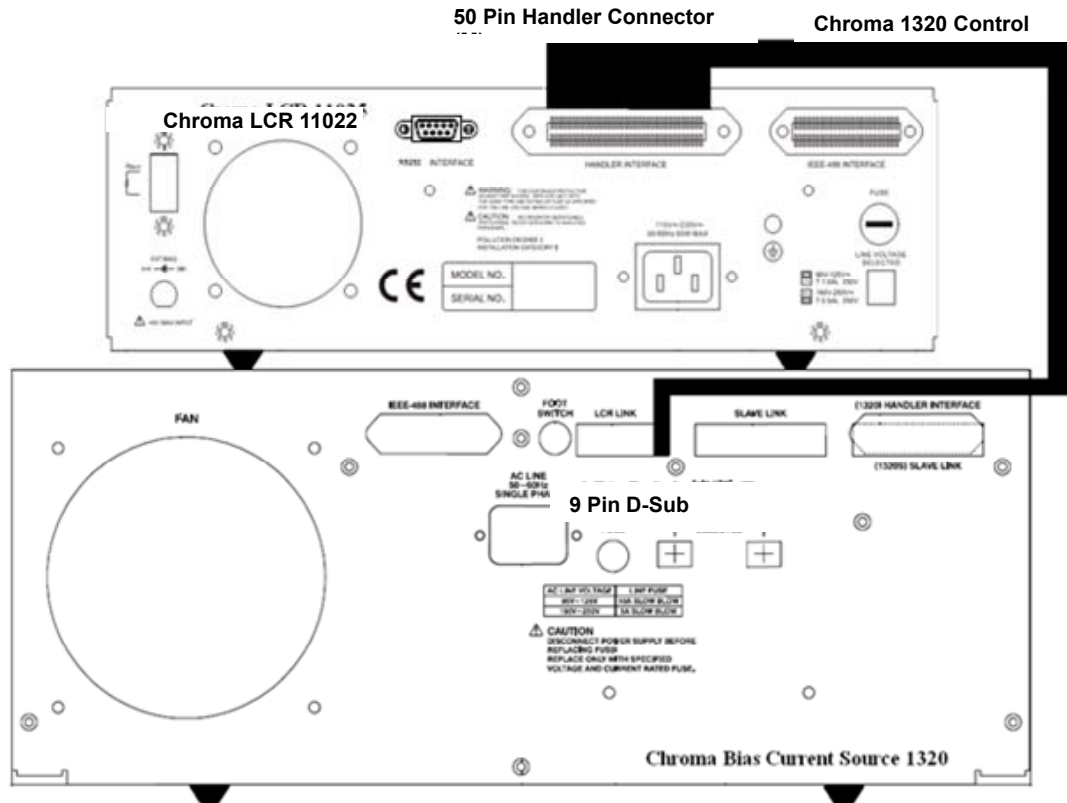

Connect 11022 LCR Meter unknown DUT socket with 1320 unknown DUT socket by using shielding wire with two ends BNC connector. The figure is shown as below. Next to set 1320 output current value and switch to ON by pressing [F1] finally to perform measurement.

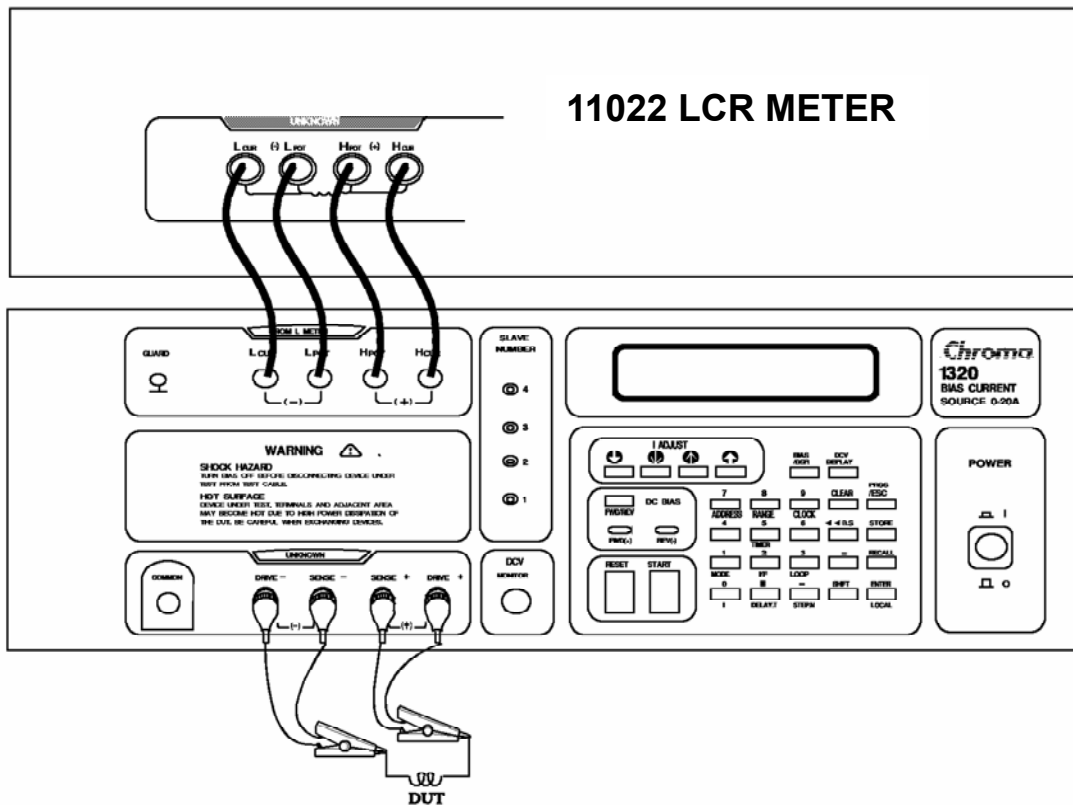

BIAS I 000.000A: It is the function for setting the value of 1320 Bias Current Source 0-10A or 1320 Bias Current Source 0-20A. Press [Δ], [∇], [\leftarrow] and [\rightarrow] to adjust the current. The factory default value is 000.000A. Please notice that the maximum current value only can be set to 10A as connecting a set of 1320 Bias Current Source 0-10A. The maximum current value can be set to 20A as connecting a set of 1320 Bias Current Source 0-20A. However, the maximum current value can be set to 40A as connecting a set of 1320 Bias Current Source 0-20A with 1320S. A set of 1320 Bias Current Source 0-20A can connect four sets of 1320S maximum, thus the maximum current value can set to 100A. The maximum current value should be noticed for avoiding 1320 burn down.

4.4.4 Binning SET

1. Turn the power on, ensure screen shows everything is OK, press [Main Index] to enter the main index as follows.

< MAIN INDEX >	BINNING	[F1] ← Binning test setting
	COMPARE	[F2] ← Compare test setting.
	CORRECTION	[F3] ← Zeroing calibration
	NEXT PAGE 1/2	[F4] ← To next page

At the same time press [F1] then enter Binning test screen as follows.

< MAIN INDEX-BINNING >		BIN SET
PARAMETER : Cp – D		STORE
NOMINAL : 00000.0000pF		RECALL
AUX_HI : +99999.9999-		BIN COUNT
AUX_LO : +00000.0000-		

- ← Bin setting.
- ← Store value setting
- ← Recall value setting
- ← Bin test count

Press [F1] then enter Bin Set screen as follows:

< MAIN INDEX-BIN SET >		DIGIT UP
PARAMETER : Cp – D		DIGIT DOWN
NOMINAL : 00000.0000pF		DIGIT
AUX_HI : +99999.9999-		
AUX_LO : +00000.0000-		

- ← The digit which cursor on for adjusting upward.
- ← The digit which cursor on for adjusting downward.
- ← Move the cursor to right for one digit.
-

Assume AUX_LO to set to –00001.800, please follow the following method to operate:

- ① Press [▽] key twice, move highlight to AUX_LO setting value. At the same time the cursor will blinking on + mark. Press [F1] key (DIGIT UP) or [F2] key (DIGIT DOWN) change + mark to – mark.
- ② Press [F3] key (DIGIT) five times, moving the cursor forward one decimal point and press [F1] key (DIGIT UP) once so that the digit 0 becomes 1.
- ③ Press [F3] key (DIGIT) once again moving the cursor to the next decimal point and press [F2] key (DIGIT DOWN) twice so that the digit 0 becomes 8.
- ④ After the setting is completed the screen should be as the following:

< MAIN INDEX-BIN SET >		DIGIT UP
PARAMETER: Cp – D		DIGIT DOWN
NOMINAL : 00000.0000pF		DIGIT
AUX_HI : +99999.9999-		
AUX_LO : +00001.8000-		

- ← The digit which cursor on for adjusting upward.
- ← The digit which cursor on for adjusting downward
- ← Move the cursor to right for one digit.
-

< MAIN INDEX-BIN SET >		DIGIT UP
BIN	HI()	LO()
1	+000.00%	-000.00%
2	+000.00%	-000.00%
3	+000.00%	-000.00%
4	+000.00%	-000.00%
		MODE: %

- ← The digit which cursor on for adjusting upward.
- ← The digit which cursor on for adjusting downward
- ← Move the cursor to right for one digit.
- ← The high/low limit of test value can set to % or ABS.

< MAIN INDEX-BIN SET >		DIGIT UP
BIN	HI()	LO()
5	+000.00%	-000.00%
6	+000.00%	-000.00%
7	+000.00%	-000.00%
8	+000.00%	-000.00%
		MODE: %

- ← The digit which cursor on for adjusting upward.
- ← The digit which cursor on for adjusting downward.
- ← Move the cursor to right for one digit.
- ← The high/low limit of test value can set to % or ABS.

The high/low limit setting of percentage (%) mode is a central value by Nominal. The absolute value (ABS) mode is setting high/low limit directly for binning test.

2. After completing as above, press [Main Index] key once then press [F4] (BIN COUNT) to enter Bin Test screen as follows:

BIN	COUNT	BIN	COUNT	
0	0	5	0	SPEED: M
1	0	6	0	TRIG. : INT
2	0	7	0	RANGE: AUTO
3	0	8	0	
4	0	OUT	1736	RESET
TOTAL:			1736	

- [F1] ← Measurement speed
- [F2] ← Trigger mode
- [F3] ← Range Auto/Hold setting
- [F4] ← Clear count value

Press [MEAS DISPLAY] key to enter main measurement screen. Then press [F4] to enter the third page for BINNING function enabling, the screen will show the current binning result as below.

< MEAS. DISPLAY >	BIAS V : OFF
Cp : 0.9999nF	BINNING : ON
D : 0.0001	COMPARE : OFF
BIN 0	NEXT PAGE 3/4

- [F1] ← Bias DCV setting
- [F2] ← Binning setting
- [F3] ← Compare setting
- [F4] ← To the 4th page

3. Description of using STORE and RECALL.

< MAIN INDEX-BIN SET >	BIN SET
PARAMETER: Cp – D	STORE
NOMINAL : 00000.0000pF	RECALL
AUX_HI : +99999.9999-	BIN COUNT
AUX_LO : +00000.0000-	

- [F1] ← Modify setting
- [F2] ← Store setting
- [F3] ← Recall setting
- [F4] ← Binning test count

After pressing [F2] key (STORE) as above, screen will show the following.

< MAIN INDEX-BIN SET >	DIGIT UP
ENTER STORE NUMBER: 00	DIGIT DOWN
PARAMETER: Cp – D	DIGIT
NOMINAL : 00000.0000pF	
AUX_HI : +99999.9999-	
AUX_LO : +00000.0000-	

- [F1] ← The digit which cursor on for adjusting upward.
- [F2] ← The digit which cursor on for adjusting downward.
- [F3] ← Move the cursor to right for one digit.
- [F4]

The store range is from 00 to 49. After setting is completed, press [Trigger] key to store. Using RECALL for BINNING setting value afterwards can avoid having to set action repeatedly. RECALL operation is the same as STORE.

When performing STORE or RECALL, memory will store or load the following parameters:

- A) FREQUENCY
- B) SPEED
- C) LEVEL
- D) PARAMETER
- E) RANGE
- F) TRIGGER MODE
- G) BIAS
- H) All BIN setting values. (Not including BIN COUNTER)
- I) All COMPARE setting values. (Not including COMPARE COUNTER)
- J) Part of setting in SYSTEM SETUP (ex. LINK 1320/IG CYCLE/KEY LOCK/AVERAGE TIME/TRIGGER DELAY).

4.4.5 Description of Compare Setting Operation

After turning on main unit power display and ensuring all is normal, press [Main Index] key to enter main function list as the following:

< MAIN INDEX >	BINNING	[F1]	← Binning test setting.
	COMPARE	[F2]	← Compare test setting.
	CORRECTION	[F3]	← Zero calibration
	NEXT PAGE 1/2	[F4]	← To the second page

At the same time, press [F2] key then enter compare setting function as follows.

< MAIN INDEX-COMPARE >	SETTING	[F1]	← Compare test setting
	STORE	[F2]	← Store setting
	RECALL	[F3]	← Recall setting
	COUNT	[F4]	← Compare test count
PARAMETER : Cp - D			
PRI_NOMINAL : +00000.0000-F			
PRI_HI_LIMIT : +00000.0000-F			
PRI_LO_LIMIT : -00000.0000-F			

Press [F1] SETTING to enter Compare Setting Screen is shown as below. For setting operation, please refer 4.4.4 *Binning SET*.

< COMPARE SET >	DIGIT UP	[F1]	← The digit which cursor on for adjusting upward.
	DIGIT DOWN	[F2]	← The digit which cursor on for adjusting downward.
	DIGIT	[F3]	← Move the cursor to right for one digit.
	MODE: ABS	[F4]	← The high/low limit of test value can set to % or ABS.
	PARAMETER : Cp - D		
	PRI_NOMINAL : +00000.0000-F		
SEC_NOMINAL : +00000.0000-F			
PRI_HI_LIMIT : +00000.0000-F			
PRI_LO_LIMIT : -00000.0000-F			
SEC_HI_LIMIT : +00000.0000-F			
SEC_LO_LIMIT : -00000.0000-F			

After the setting is completed, press [Main Index] key to return to previous screen (as above figure). Next, press [F4] key (COUNT) to start the test. The test screen will be shown as the following.

< MAIN INDEX-COMPARE >	SPEED : M	[F1]	← Measuring speed setting
	TRIG. : INT	[F2]	← Trigger mode
	RANGE : AUTO	[F3]	← Range Auto/Hold setting
	RESET	[F4]	← Clear count value
	PRIMARY COUNT SECOND		
	COUNT		
GO : 2725 GO : 2725			
HI : 0 HI : 0			
LO : 0 LO : 0			
TOTAL : 2725			

Press [MEAS DISPLAY] key to enter main measurement screen. Then press [F4] to enter the third page for COMPARE function enabling, the screen will show the current compare result as below.

< MEAS. DISPLAY >	BIAS V: OFF	[F1]	← External DCV setting
	BINNING: OFF	[F2]	← Binning setting
	COMPARE: ON-VAL	[F3]	← Compare setting
	NEXT PAGE 3/4	[F4]	← To the 4 th page
Cp : 0.9999nF			
D : 0.0001			
Cp : HI D : HI			

Press [F3], meanwhile compare setting function will show difference absolute value of primary parameter and COMPARE nominal value. The screen is shown as below.

< MEAS. DISPLAY – ΔABS >		BIAS V: OFF	F1 ← External DCV setting
Cp :	0.0001nF	BINNING: OFF	F2 ← Binning setting
D :	0.0001	COMPARE: ON-Δ	F3 ← Compare setting
Cp : HI	D : HI	NEXT PAGE 3/4	F4 ← To the 4 th page

Press [F3], meanwhile compare setting function will show difference value percentage of primary parameter and COMPARE nominal value. The screen is shown as below.

< MEAS. DISPLAY – Δ% >		BIAS V: OFF	F1 ← External DCV setting
Cp :	00.00%	BINNING: OFF	F2 ← Binning setting
D :	0.0001	COMPARE: ON-Δ%	F3 ← Compare setting
Cp : HI	D : HI	NEXT PAGE 3/4	F4 ← To the 4 th page

For STORE, RECALL functions please refer 4.4.4 Binning SET.

4.4.6 Bias Compare

- After turning on main unit power display and ensuring all are normal, press [SYSTEM SETUP] to enter system parameter operation setting. Moreover, press [▽] several times to enter Bias Compare Mode setting which contains Slave device and Master device shown as below.

<SYSTEM CONFIG>		SLAVE	F1 ← Slave device
BIAS C. MODE: SLAVE		MASTER	F2 ← Master device
			F3
			F4

- First select SLAVE MODE then press [Main Index] to enter MAIN INDEX and next to press [F4] to go to the 2nd page as below shown.

< MAIN INDEX >		BINNING	F1 ← Binning test setting
		COMPARE	F2 ← Compare test setting
		CORRECTION	F3 ← Zeroing correction
		NEXT PAGE 1/2	F4 ← To the 2 nd page

< MAIN INDEX >		BIAS COMPARE	F1 ← Bias compare setting
		DUAL FREQ.	F2 ← Dual frequency function setting
			F3
		NEXT PAGE 2/2	F4 ← To the 1 st page

At this time, press [F1] to enter bias compare test setting screen as follows.

<MAIN INDEX-BIAS COMPARE >		SETTING	F1 ← Bias compare test setting
PARAMETER: Ls-Q		STORE	F2 ← Store setting value
Ls O_NOMINAL: 000.000-H		RECALL	F3 ← Recall setting value
Hi : 000.000-H Lo: 000.000-H		TEST	F4 ← Bias compare test
QO_Lo_LIMIT : 000.000-			

Press [F1] SETTING to enter setting value modification screen is shown as below. For setting operation, please refer 4.4.4 Binning SET.

<MAIN INDEX-BIAS COMP. SET > Ls O_NOMINAL: 600.000uH Hi: 630.000uH Lo: 570.000uH QO_Lo_LIMIT: 070.000 Ls B_Hi : 550.000uH Ls B_Lo: 500.000uH QB_Lo_LIMIT: 070.000-	DIGIT UP	F1	← The digit which cursor on for adjusting upward.
	DIGIT DOWN	F2	← The digit which cursor on for adjusting downward.
	DIGIT	F3	← Move the cursor to right for one digit.
		F4	

The DUT inductance and Q value of the primary with or without loading current are LsO and QO. The DUT inductance and Q value of the secondary with loading current are LsB and QB. Thus, the DUT secondary measuring of un-adding and adding loading current can be performed. The DUT secondary measuring loading under different currents also can be performed. The test frequency is for MEAS DISPLAY in main screen.

Bias compare setting SLAVE MODE function can be used only when make a connection of 50 Pin Handler interface and 1320 Bias Current Source 0-10A or 1320 Bias Current Source 0-20A by using Chroma 1320 control line in Table 1-2 Optional Accessory. The connection is shown as below. To avoid control signal interferes each other, please be careful that 24 Pin Handler connector (M) and 9 Pin D-SUB connector (F) of Chroma 1320 control line can't be connected simultaneously. Meanwhile, 24 Pin Handler connector (M) should be connected and power off the two units and then perform connection.

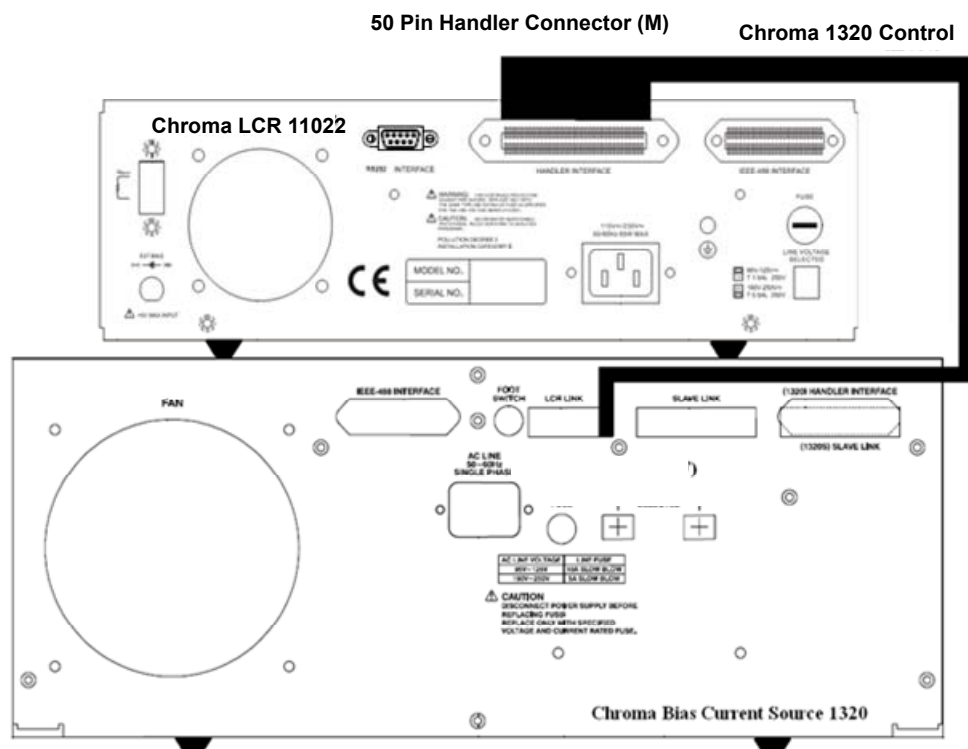

After setting is completed, press [Main Index] to return to previous screen. Next, press [F4] (TEST) to start test. The test screen will be shown as below. R1 and R2 are range setting for the primary and secondary measurement.

<MAIN INDEX-BIAS COMP. TEST >		SPEED: M	F1 ← Measurement speed setting
LsO : 0.6450mH	Hi	TRIG.: EXT	F2 ← Trigger mode setting
QO : 87.6	GO	R1:A 10Ω	F3 ← The primary measurement range setting
LsB : 0.6040mH	GO FAIL	R2: A 10Ω	F4 ← The secondary measurement range setting
QB : 86.5	NG		

Please change trigger mode to External, and then use Handler connection wire for connecting Handler interface of 11022 to that of 1320 Bias Current Source 0-10A or 1320 Bias Current Source 0-20A. The unknown DUT's socket of 11022 LCR Meter connects with that of 1320, its connection method is the same as the function of LINK 1320. At last, turn on 1320 Bias Current Source 0-10A or 1320 Bias Current Source 0-20A to start measurement. The 1320 needs to set Handler and two-point measurement modes then performs trigger measurement by using red START key on 1320. There will be the data of two measurements, they compare with the previous setting values respectively. The right side of parameter shows Lo (means inductance value lower than setting value), Hi (means inductance value higher than setting value), GO (means inductance or Q value meet to the setting requirement) along with NG (means Q value lower than setting value). The middle in the monitor shows PASS or FAIL after synthesized comparison results of various parameters.

3. Press [Main Index] to enter main menu and press [F4] to enter the 2nd page if MASTER MODE is selected. Meanwhile, press [F1] to enter bias compare setting screen is shown as below.

<MAIN INDEX-BIAS COMPARE >		SETTING	F1 ← Bias compare test setting
PARAMETER: Ls-Q		STORE	F2 ← Store setting value
Ls O_NOMINAL: 000.000-H		RECALL	F3 ← Recall setting value
Hi : 000.000-H	Lo: 000.000-H	TEST	F4 ← Bias compare test
QO_Lo_LIMIT : 000.000-			

Press [F1] SETTING to enter setting value modification screen is shown as below.

<MAIN INDEX-BIAS COMP. SET >		DIGIT UP	F1 ← The digit which cursor on for adjusting upward.
Ls O_NOMINAL: 600.000uH		DIGIT DOWN	F2 ← The digit which cursor on for adjusting downward.
Hi: 630.000uH	Lo: 570.000uH	DIGIT	F3 ← Move the cursor to right for one digit.
QO_Lo_LIMIT: 070.000			F4
Ls B_Hi: 550.000uH			
Ls B_Lo : 500.000uH			
QB_Lo_LIMIT: 070.000			

The above screen contains more 1320 Bias Current Source setting than Slave Mode screen. The user can set needed 1320 loading current directly from this screen. For setting operation please see 4.4.4 *Binning SET*. LsO and QO should be DUT's inductance and Q value of no loading current under MASTER MODE operation. LsB and QB are DUT's inductance and Q value of the second time with loading current, thus the tester can execute DUT secondary measurement un-add loading current and add loading current. The test frequency is for MEAS DISPLAY in main screen.

The aspect of parameter setting consists of Absolute (ABS) and Percentage (%) modes are shown as below.

<MAIN INDEX-BIAS COMP. SET > Ls O_NOMINAL: 600.000uH Hi: 630.000uH Lo: 570.000uH QO_Lo_LIMIT: 070.000 Ls B_Hi : 550.000uH Ls B_Lo : 500.000uH QB_Lo_LIMIT: 070.000-	DIGIT UP	F1 ← The digit cursor on for adjusting upward
	DIGIT DOWN	F2 ← The digit cursor on for adjusting downward
	DIGIT	F3 ← Move the cursor to right for one digit
	MODE: ABS	F4 ← The high/low limit of test value can set % or ABS

The settings are only for the high/low limit of LsO and LsB when Percentage (%) is selected. Since LsB is without nominal setting, thus percentage nominal for setting is mainly on LsO_NOMINAL parameter.

<MAIN INDEX-BIAS COMP. SET > Ls O_NOMINAL: 600.000uH Hi: +001.0% Lo: -0.010% QO_Lo_LIMIT : 070.000 Ls B_Hi : +005.0%(Measure LsO) Ls B_Lo : -005.0%(Measure LsO) QB_Lo_LIMIT: 070.000-	DIGIT UP	F1 ← The digit cursor on for adjusting upward
	DIGIT DOWN	F2 ← The digit cursor on for adjusting downward
	DIGIT	F3 ← Move the cursor to right for one digit
	MODE: %	F4 ← The high/low limit of test value can set % or ABS

Bias compare setting MASTER MODE function can be used only when make a connection of 50 Pin Handler interface and 1320 Bias Current Source 0-10A or 1320 Bias Current Source 0-20A by using Chroma 1320 control line in Table 1-2 Optional Accessory. The connection is shown as below. To avoid control signal interferes each other, please be careful that 24 Pin Handler connector (M) and 9 Pin D-SUB connector (F) of Chroma 1320 control line can't be connected simultaneously. Meanwhile, 9 Pin D-SUB connector (F) should be connected and power off the two units and then perform connection.

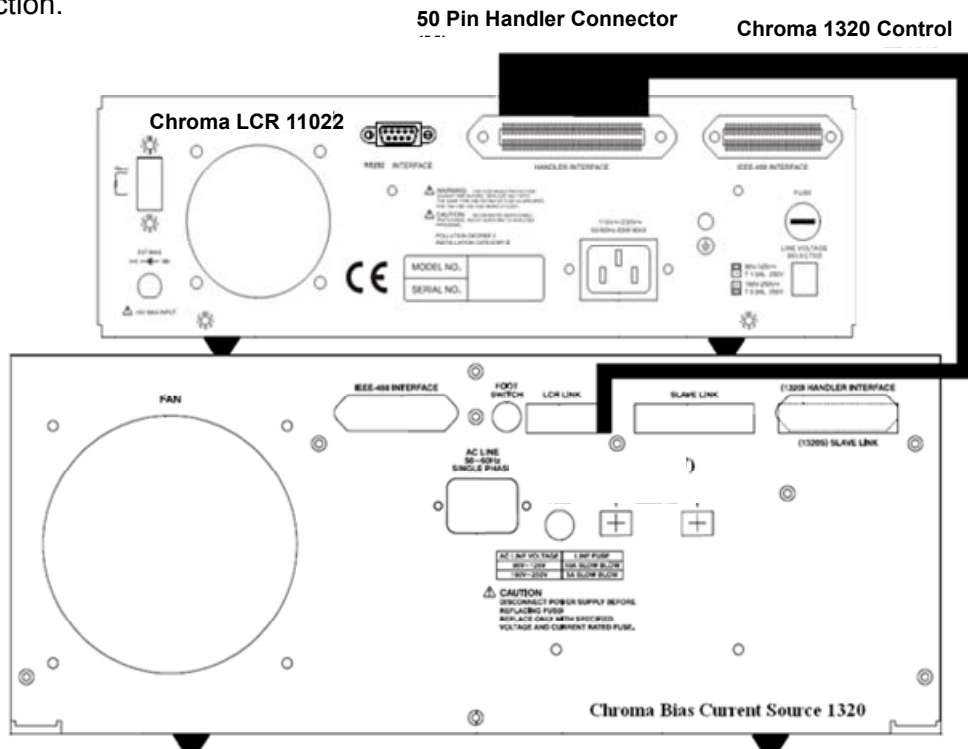

The Bias Compare MASTER MODE parameter setting is more a 1320 current setting than SLAVE MODE. To set the 1320's output current from the meter directly is shown below.

<MAIN INDEX-BIAS COMP. SET > Ls O_NOMINAL: 600.000uH Hi: 630.000uH Lo: 570.000uH QO_Lo_LIMIT: 070.000 Ls B_Hi: 550.000uH Ls B_Lo : 500.000uH QB_Lo_LIMIT: 070.000- I: 001.000A	<table border="1" style="border-collapse: collapse; width: 100%;"> <tr><td style="text-align: center;">DIGIT UP</td></tr> <tr><td style="text-align: center;">DIGIT DOWN</td></tr> <tr><td style="text-align: center;">DIGIT</td></tr> </table>	DIGIT UP	DIGIT DOWN	DIGIT
DIGIT UP				
DIGIT DOWN				
DIGIT				

F1	← The digit cursor on for adjusting upward
F2	← The digit cursor on for adjusting downward
F3	← Move the cursor to right for one digit
F4	

The monitor will show NO BIAS SOURCE for hinting if BIAS COMPARE start test screen to be entered but 1320 unconnected will cause abnormal measuring. The screen is shown as below. Press any key to escape from this screen. Please power off then follow above described connection for well connected. Thus, power the instrument on to perform the test.

<MAIN INDEX-BIAS COMPARE > NO BIAS SOURCE PRESS ANY KEY TO ESCAPE ...!	<table border="1" style="border-collapse: collapse; width: 100%;"> <tr><td style="text-align: center;">SETTING</td></tr> <tr><td style="text-align: center;">STORE</td></tr> <tr><td style="text-align: center;">RECALL</td></tr> <tr><td style="text-align: center;">TEST</td></tr> </table>	SETTING	STORE	RECALL	TEST
SETTING					
STORE					
RECALL					
TEST					

F1	← Bias compare test setting
F2	← Store setting value
F3	← Recall setting value
F4	← Bias compare test

Press [F4] TEST to enter test screen is shown as below if the connection is all right. Please set the trigger mode to manual trigger (MAN).

<MAIN INDEX-BIAS COMP. TEST > LsO : H QO : LsB : H QB :	<table border="1" style="border-collapse: collapse; width: 100%;"> <tr><td style="text-align: center;">SPEED: M</td></tr> <tr><td style="text-align: center;">TRIG: MAN</td></tr> <tr><td style="text-align: center;">R1: A 1.0MΩ</td></tr> <tr><td style="text-align: center;">R2: A 1.0MΩ</td></tr> </table>	SPEED: M	TRIG: MAN	R1: A 1.0MΩ	R2: A 1.0MΩ
SPEED: M					
TRIG: MAN					
R1: A 1.0MΩ					
R2: A 1.0MΩ					

F1	← Measurement speed setting
F2	← Trigger mode setting
F3	← The primary measurement range setting
F4	← The secondary measurement range setting

Press [TRIGGER] to trigger performing measurement is shown as below. Its judgment method for parameter measurement result is the same as SLAVE MODE.

<MAIN INDEX-BIAS COMP. TEST > LsO : 0.6450mH Hi QO : 87.6 GO FAIL LsB : 0.6040mH GO QB : 86.5 NG	<table border="1" style="border-collapse: collapse; width: 100%;"> <tr><td style="text-align: center;">SPEED: M</td></tr> <tr><td style="text-align: center;">TRIG: MAN</td></tr> <tr><td style="text-align: center;">R1: A 10Ω</td></tr> <tr><td style="text-align: center;">R2: A 10Ω</td></tr> </table>	SPEED: M	TRIG: MAN	R1: A 10Ω	R2: A 10Ω
SPEED: M					
TRIG: MAN					
R1: A 10Ω					
R2: A 10Ω					

F1	← Measurement speed setting
F2	← Trigger mode setting
F3	← The primary measurement range setting
F4	← The secondary measurement range setting

If TEST FAIL in system parameter set to CONTINUE is given below, although the first test result displays error, the second test is still executed as the screen shown above.

<SYSTEM CONFIG> BIAS C. MODE : MASTER TEST FAIL : CONTINUE BAUDRATE : NONE	<table border="1" style="border-collapse: collapse; width: 100%;"> <tr><td style="text-align: center;">CONTINUE</td></tr> <tr><td style="text-align: center;">STOP</td></tr> </table>	CONTINUE	STOP
CONTINUE			
STOP			

F1	← Test continuously
F2	← Fail and stop test
F3	
F4	

If TEST FAIL in system parameter set to STOP is given below, that is the first test result displays error and then the second test won't be executed the screen shown as below.

<SYSTEM CONFIG> BIAS C. MODE : MASTER CONTINUE TEST FAIL : STOP BAUDRATE : NONE STOP	F1 ← Test continuously F2 ← Fail and stop test F3 F4
--	---

<MAIN INDEX-BIAS COMP. TEST > LsO : 0.6450mH Hi QO : 87.6 GO LsB : QB :	SPEED: M TRIG.: MAN R1: A 10Ω R2: A 10Ω	F1 ← Measurement speed setting F2 ← Trigger mode setting F3 ← The primary measurement range setting F4 ← The secondary measurement range setting
--	--	---

The 1320 doesn't power on if the connection is correct, it may cause abnormal measuring. The upper left at monitor will show BIAS I NOT SET for hinting is shown as below. Power on the 1320 and then press [TRIGGER] for performing measurement.

<MAIN INDEX-BIAS COMP. TEST > BIAS I NOT SET LsO : H QO : LsB : H QB :	SPEED: M TRIG.: MAN R1: A 1.0MΩ R2: A 1.0MΩ	F1 ← Measurement speed setting F2 ← Trigger mode setting F3 ← The primary measurement range setting F4 ← The secondary measurement range setting
--	--	---

The 1320 occurs "I SRC ERROR" or "V SNK ERROR" state in testing DUT parameter of secondary measurement loading current. The top left at monitor will show BIAS I NOT SET for hinting is shown as below. Please do troubleshooting for 1320 or DUT measurements then press [TRIGGER] to perform measuring. Please notice the meter will wait a period of time to detect if the 1320 loading current is normal when performing the secondary measurement. The maximum waiting time is 5 seconds. The screen as below will be shown if the waiting time is over 5 seconds. Therefore, the 1320 delay time can't over 5 seconds or it may cause measurement procedure blocked.

<MAIN INDEX-BIAS COMP. TEST > BIAS I NOT SET LsO : 0.6450mH Hi QO : 87.6 GO LsB : H QB :	SPEED: M TRIG.: MAN R1: A 10Ω R2: A 1.0MΩ	F1 ← Measurement speed setting F2 ← Trigger mode setting F3 ← The primary measurement range setting F4 ← The secondary measurement range setting
--	--	---

The user touches any key of the tester in testing DUT parameter of secondary measurement loading current. This will make the measurement process pause; meanwhile top left at monitor will show USER STOP for hinting is shown as below. If the 1320 doesn't output loading current, press [TRIGGER] to go measuring. If the 1320 already output loading current, press [TRIGGER] to disable START state or press [RESET] and then [TRIGGER] to go measuring.

<MAIN INDEX-BIAS COMP. TEST > USER STOP LsO : 0.6450mH Hi QO : 87.6 GO LsB : H QB :	SPEED: M TRIG.: MAN R1: A 10Ω R2: A 1.0MΩ	F1 ← Measurement speed setting F2 ← Trigger mode setting F3 ← The primary measurement range setting F4 ← The secondary measurement range setting
---	--	---

- The DUT is without adding loading current if user measuring first time to do BIAS COMPARE measurement by using MASTER MODE is recommended. It can save the time of measurement and fix the range on the appropriate position to promote the speed of measurement.
- The 24 Pin Handler connector (M) is able to input control signal or output judgment signal as using MASTER MODE with Chroma 1320 control line for performing BIAS COMPARE measurement. It is for the use of automatic equipment, the pins are shown below.

Pin No.	Name	Description
1	/EXT	External trigger
2	X	N.C
3, 20	O B NG	The original secondary parameter value is not in specification.
4, 24	O A NG	The original primary parameter value is not in specification.
5-7	COM	COMMON
8	GND	Ground
9, 13	GO	The original and BIAS primary/secondary test values are in specification.
10	VEXT	External DC voltage acceptable voltage range is 5V ~ 24V.
11	VINT	Internal DC voltage +5V
12-13	X	N.C
14	O B GO	The original secondary parameter value is in specification.
15	B B NG	The BIAS secondary parameter value is not in specification.
16	B A GO	The BIAS primary parameter value is in specification.
17	B B GO	The BIAS secondary parameter value is in specification.
18	EOT	End of Test
19	B A NG	The BIAS primary parameter value is not in specification.
21	O A GO	The original primary parameter value is in specification.
22	ACQ	Analog sampling end, move the next DUT to 11022 test terminal
23	NG	The original and BIAS primary/secondary test values have one among them not in specification.

4.4.7 Description of Loading Correction Function

- After turning on main unit power display and ensuring all is normal, press [Main Index] to enter the main function screen as follows:

< MAIN INDEX > 	BINNING	[F1] ← Binning setting
	COMPARE	[F2] ← Compare setting
	CORRECTION	[F3] ← Zero correction
	NEXT PAGE 1/2	[F4] ← To the second page

Press [F3], the screen shown as follows.

< MAIN INDEX-CORRECT > 	OPEN	[F1]
	SHORT	[F2] ← Open correction
	LOAD	[F3] ← Short correction
		[F4] ← Load correction function

Press [F4], the screen shown as follows.

<MAIN INDEX-CORRECT LOAD>	ON	[F1] ← Enable LOAD function
LOAD: OFF	OFF	[F2] ← Disable LOAD function
FREQUENCY: 1.0KHz		[F3]
PARAMETER: Rs-Xs	MEAS. LOAD	[F4] ← Measure parameter actual value
REF. A VAL: +00000.0000-Ω		
MEAS A VAL: Ω		
REF. B VAL: +00000.0000-Ω		
MEAS B VAL: Ω		

Set the frequency and parameter requires along with parameter reference value desire to set then turn LOAD function on. If you press [F4], the screen will show the actual parameter measurement value. If you press [MEAS DISPLAY], the measurement value will show the parameter reference value previous set.

2. Use LOAD function to measure another DUT, it is necessary to use the same parameter and frequency under the previous opened LOAD function. The previous LOAD DUT is as a correction standard to process measurement operation.
3. When the measurement is completed or don't need this function, please close LOAD function to avoid the next time measurement affected.

4.4.8 Operation of Bin Sorting 99 Groups

1. After turning on the main unit power and displaying all are normal, press [System Setup] to enter the following screen:

< SYSTEM SETUP >	CALIBRATION	[F1] ← This key is for entering system calibration.
	MEM MANAGE	[F2] ← This key is for entering memory management.
	SYSTEM CONFIG	[F3] ← This key is for entering system configuration.
		[F4]

Press [F3] to enter [SYSTEM CONFIG] and set BIN NO>9: from OFF to ON.

<SYSTEM CONFIG>	ON	[F1] ← Enable
INTEG.CYCLE : 04		[F2] ← Disable
CONTRAST : 07	OFF	[F3]
SOUND MODE : FAIL		[F4]
ALARM MODE : PULSE		
HANDLER MODE: CLEAR		
BIN NO>9 : ON		

2. Press [MAIN INDEX] and [F1] to enter Binning setting screen.

< MAIN INDEX >	BINNING	[F1] ← Binning setting
	COMPARE	[F2] ← Compare setting
	CORRECTION	[F3] ← Zero correction.
	NEXT PAGE 1/2	[F4] ← To the second page

At the same time, press [F1] to enter binning test screen is as below:

< MAIN INDEX-BINNING >	BIN SET
PARAMETER: Cp – D	STORE
NOMINAL : 00000.0000pF	RECALL
AUX_HI : +99999.9999-	
AUX_LO : +00000.0000-	

- [F1] ← Bin setting
- [F2] ← Store setting value
- [F3] ← Recall setting value
- [F4]

Press [F1] then enter Bin Setting screen is as below:

< MAIN INDEX-BINNING >	DIGIT UP
PARAMETER: Cp – D	DIGIT DOWN
NOMINAL : 00000.0000pF	DIGIT
AUX_HI : +99999.9999-	
AUX_LO : +00000.0000-	

- [F1] ← The digit which cursor on for adjusting upward.
- [F2] ← The digit which cursor on for adjusting downward.
- [F3] ← Move the cursor to right for one digit.
- [F4]

After setting NOMINAL, AUX_HI and AUX_LO, press [▽] to enter Bin number setting screen.

< MAIN INDEX-BIN SET >	DIGIT UP
BIN NO HI(H) LO(H)	DIGIT DOWN
01 +000000.000- +00000.0000-	DIGIT
	MODE:ABS

- [F1] ← The digit which cursor on for adjusting upward.
- [F2] ← The digit which cursor on for adjusting downward.
- [F3] ← Move the cursor to right for one digit.
- [F4] ← Mode selection includes ABS and %

Bin No is bin number you want to set, from group 1 to 99. HI is the high limit of measurement range and LO is the low limit of that. Mode selection includes ABS and %.

When you select ABS mode, a group of bin range is:

$$\frac{\text{HI measurement value} - \text{LO measurement value}}{\text{BIN Number}}$$
 For instance, BIN set as 50, MODE = ABS, high limit is 100 kΩ and low limit is 0Ω then a group of bin range = $\frac{(100\text{K}\Omega - 0)}{50} = 2\text{K}\Omega$. Thus, the measurement value from 0 to 2k is BIN1, from 9k to 10k is BIN5, from 49k to 50k is BIN25, from 99k to 100k is BIN50 and so forth.

When you select % mode, a group of bin range is:

$$\frac{(\text{NOMINAL value} * \text{HI}\% - \text{NOMINAL value} * \text{LO}\%)}{\text{BIN Number}}$$
 For instance, BIN set as 20, MODE = %, high limit is 100%, low limit is -100% and NOMINAL=50kΩ then a group of bin range: $\frac{[50\text{K}\Omega * 100\% - 50\text{K}\Omega * (-100\%)]}{20} = 5\text{K}\Omega$. Thus, the measurement value from 0k to 5k is BIN1, from 5k to 10k is BIN2, from 95k to 100k is BIN20 and so forth.

Binning function is activated when the users press [MEAS DISPLAY] to enter main measurement screen next to press [F4] to go to the option in the 3rd page. The screen is given as follows. The screen can show binning group result currently.

< MEAS. DISPLAY >	BIAS V: OFF
Cp : 0.9999nF	BINNING: ON
D : 0.0001	COMPARE: OFF
BIN 0	NEXT PAGE 3/4

- [F1] ← External DCV setting
- [F2] ← Binning setting
- [F3] ← Compare setting
- [F4] ← To the 4th page

About the functions of STORE and RECALL please see 4.4.4 Binning SET.

4.4.9 Dual Frequency Function (Option)

1. Dual frequency function is mainly operating DUT capacitor parameter of multi-bandwidth. For example, Multi-layer Ceramic Capacitor (MLCC) applies to integrated circuit and filtering circuit its operation bandwidth is extra widely. The capacitance value should be measured in lower operation frequency, whereas ESR value should be noticed in higher operation frequency. The capacitor with high ESR value will has a voltage drop to influence filtering effect. Thus usually set the first test frequency to 1kHz for measuring C and D values and set the second test frequency to 100kHz for measuring ESR value. The electrolytic capacitor applies to rectified filter circuit which needs to concern capacitance value. To consider capacitor ESR value to reduce output voltage ripple current when it applies to high frequency switching power circuit. Therefore, the first test frequency usually being set to 120kHz for measuring C and D values and the second test frequency being set to 100kHz for measuring ESR value.

The dual frequency function is applied to automation dual frequency measurement and quality inspection of Electrolytic Capacitor, Multi-layer Ceramic Capacitor (MLCC) and Film Capacitor. It is for saving test time and test station as well as enhancing production capability.

Example:

Electrolytic Capacitor: 120Hz C/D and 100kHz ESR

MLCC (DC to DC application, non-high-Q value communication application): 1kHz C/D and 100kHz ESR

Film Capacitor: 1kHz C/D and 100kHz D

2. It is needed to set trigger delay time before performing dual frequency function operation. Press [System Setup] to enter the screen as below.

< SYSTEM SETUP >	CALIBRATION	F1	← Press this key to enter system calibration screen
	MEM MANAGE	F2	← Press this key to enter memory management
	SYSTEM CONFIG	F3	← Press this key to enter system configuration screen
		F4	

Press [F3] to enter [SYSTEM CONFIG] for setting the required trigger delay time.

<SYSTEM CONFIG> GPIB EOS CODE : 0Ah GPIB ADDRESS : 17 TRIGGER DELAY : 0000 mS TRIGGER EDGE : FALLING LINK 1320 : OFF HARM CHECK : OFF	DIGIT UP	F1	← The digit which cursor on for adjusting upward.
	DIGIT DOWN	F2	← The digit which cursor on for adjusting downward.
	DIGIT	F3	← Move the cursor to right for one digit.
		F4	

The required trigger delay time need combine with output impedance (Constant Mode) as well as make selection in [SYSTEM CONFIG] menu as below screen shown. There are four modes for selection. About the various mode definitions please see 2.2 *Test Signals*.

<SYSTEM CONFIG> VM/IM DISPLAY : OFF CONST RSOURCE : 100/25 OHM AVERAGE TIME : 001 CABLE LENGTH : 0M BEEPER : LOW KEY LOCK: OFF	100/25 OHM	F1	← 100/25 OHM mode
	100OHM	F2	← 100 OHM mode
	10 OHM/C.C	F3	← 10 OHM constant current mode
	Next. P 1/2	F4	← To the 2 nd page

<SYSTEM CONFIG>		
VM/IM DISPLAY	: OFF	25 OHM
CONST RSOURCE	: 100/25 OHM	
AVERAGE TIME	: 001	
CABLE LENGTH	: 0M	
BEEPER	: LOW	
KEY LOCK	: OFF	
		Next. P 2/2

← 25 OHM mode

← To the 1st page

The calculation of trigger delay time is decided by DUT capacity. Trigger delay time (T_{DELAY}) $5 \times R_{OUT} \times C_{DUT}$ second is recommended if the DUT capacity is C_{DUT} and output impedance range is R_{OUT} as well as two test frequencies are above 100Hz. The accuracy can up to 99.33% of the meter. Be able to set trigger delay time over $5 \times R_{OUT} \times C_{DUT}$ second for more measurement accuracy. Add test time for 20ms if one of test frequencies is 50Hz or 60Hz, thus T_{DELAY} should be $(5 \times R_{OUT} \times C_{DUT} + 20 \times 10^{-3})$ second.

If the users select the output impedance of the meter is 10 OHM/C.C. mode. The output impedance is 10 OHM when the measurement range is 10Ω, 100Ω, 300Ω or 1kΩ. Moreover, the output impedance is 50 OHM when the measurement range is 100mΩ, 1Ω, <10Ω, 3kΩ, 10kΩ, 30kΩ, 100kΩ, 300kΩ or 1.0MΩ. Thus, the DUT's measurement contains the above two types of range as operating dual frequency function. Meanwhile, the output impedance will be changed so the output impedance (R_{OUT}) of TRIGGER DELAY doing calculation by 50Ω is recommended.

If the users select the output impedance of the meter is 100/25Ω mode. The meter will select 25Ω for output impedance when the DUT's measurement range is below 1Ω. Moreover, the meter will choose 100Ω for output impedance if the DUT's measurement range is over 10Ω. Thus, the DUT's measurement contains the above two types of range as operating dual frequency function. Meanwhile, the output impedance will be changed so the output impedance (R_{OUT}) of TRIGGER DELAY doing calculation by 100Ω is recommended.

For example, the output impedance selected by the meter is 25 OHM when C_{DUT} is 330uF. The test frequencies are 120Hz and 100kHz respectively, thus the TRIGGER DELAY time (T_{DELAY}) should be $5 \times R_{OUT} \times C_{DUT} = 5 \times 25\Omega \times 330 \times 10^{-6} = 41.25ms$

- Press [Main Index] to enter main function page after powering on the instrument and showing all are normal. Next to press [F4] to enter the 2nd page is shown as below.

< MAIN INDEX >		
	BINNING	<input type="button" value="F1"/> ← Binning test setting
	COMPARE	<input type="button" value="F2"/> ← Compare test setting
	CORRECTION	<input type="button" value="F3"/> ← Zero correction
	NEXT PAGE 1/2	<input type="button" value="F4"/> ← To the 2 nd page

< MAIN INDEX >		
	BIAS COMPARE	<input type="button" value="F1"/> ← Bias compare setting
	DUAL FREQ.	<input type="button" value="F2"/> ← Dual frequency setting
		<input type="button" value="F3"/>
	NEXT PAGE 2/2	<input type="button" value="F4"/> ← To the 1 st page

Press [F2] to go to dual frequency test screen is shown as below.

< MAIN INDEX-DUAL FREQ. >		SETTING
1ST PARA: Cp-D	FREQ: 1.0KHz	STORE
NOMINAL:	+00000.0000-F	RECALL
2ND PARA: D	FREQ: 1.0KHz	TEST

- [F1] ← Dual frequency function setting
- [F2] ← Store setting
- [F3] ← Recall setting
- [F4] ← Dual frequency function test

Press [F1] to go to modification setting screen is shown as below.

<MAIN INDEX-DUAL FREQ. SET>		DIGIT UP
1ST PARA: Cp-D	FREQ: 1.0KHz	DIGIT DOWN
NOMINAL:	+00000.0000-F	DIGIT
2ND PARA: D	FREQ: 1.0KHz	
AUX HI LO		
1ST +00000.0000-	-00000.0000-	
2ND +00000.0000-	-00000.0000-	

- [F1] ← The digit which cursor on for adjusting upward.
- [F2] ← The digit which cursor on for adjusting downward.
- [F3] ← Move the cursor to right for one digit.
- [F4]

The option of 1ST PARA is the parameter of 1st measurement which can set primary, secondary parameter; test frequency and nominal value. The option of 2ND PARA is the parameter of 2nd measurement which only can set secondary parameter and test frequency. The options of AUX 1ST and 2ND are respectively for setting the secondary parameter high and low value in the 1st and 2nd measurement.

Press  to enter dual frequency BIN number setting screen after setting is completed. Be able to set four groups of binning conditions at most. The operation please see 4.4.4 *Binning SET*.

<MAIN INDEX-DUAL FREQ. SET>			DIGIT UP
BIN	HI()	LO()	DIGIT DOWN
1	+000.00%	-000.00%	DIGIT
2	+000.00%	-000.00%	
3	+000.00%	-000.00%	
4	+000.00%	-000.00%	MODE: %

- [F1]
- [F2]
- [F3]
- [F4] ← The high/low limit of test value can set to % or ABS

Press [Main Index] to back to the previous screen as above after setting is completed. Next to press [F4] (TEST) to start testing the screen is shown below.

<MAIN INDEX-DUAL FREQ.>		SPEED: FAST
Cp : -0.26pF	BIN OUT	TRIG: INT
D 1: 0.1015	NOGO	RNG.1: A 1.0MΩ
D 2: 0.7315	NOGO	RNG.2: A 1.0MΩ

- [F1] ← Measurement speed
- [F2] ← Trigger mode
- [F3] ← The 1st measurement range setting
- [F4] ← The 2nd measurement range setting

About the functions of STORE and RECALL please see 4.4.4 *Binning SET*.

5. Description of GPIB/RS-232 Interface

5.1 Overview

Using the IEEE-488.2 interface, the users can operate the 11022 by remote control, transfer data and etc. The RS-232 interface is for option. This chapter is mainly for providing the description of the 11022 interface Bus (GPIB) or RS-232 command for the users' writing program to control the 11022 in order to do test data process. Please notice that only can choose GPIB or RS-232 interface for use.

5.2 GPIB Interface Specification

5.2.1 IEEE- 488 Interface Function

Code	Meaning
SH1	Source handshake (talker)
AH1	Acceptor handshake (listener)
T6	Basic talker function
	Serial poll function
	Listener-specified talker release function
	No TALK ONLY function
L4	Basic listener function
	Talker-specified listener release function
SR1	All service request functions
RL1	All remote-local functions
PP0	No parallel poll function
DC1	Device clear function
DT1	Device trigger function
C0	No controller function

5.2.2 Using Code

ISO(ASCII) Code.

5.2.3 TALK/LISTEN Function

“TALK/LISTEN” denotes full programmability and is suited for use in a system that has a controller to manage the data flow.

5.2.4 IEEE-488 Interface Connector

- Pin configuration of the meter side connector is as below shown.

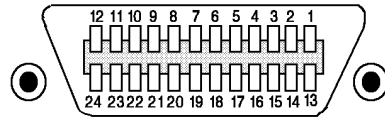

1 DIO1	13 DIO5
2 DIO2	14 DIO6
3 DIO3	15 DIO7
4 DIO4	16 DIO8
5 EOI	17 REN
6 DAV	18 GND
7 NRFD	19 GND
8 NDAC	20 GND
9 IFC	21 GND
10 SRQ	22 GND
11 ATN	23 GND
12 SHIELD	24 LOGIC GND

- Meter side connector
DDK 57 LE- 20240 or equivalent.
- Cable side connector.
DDK 57-10240 or equivalent.

5.2.5 Signal Lines of the IEEE-488 Interface Bus

- The interface is composed of the data bus, the handshake bus and the control bus shown in the table below:

	Bus Signal Lines	Description
Data Bus	DIO 1 (Data Input Output1) 2 (Data Input Output 2) 3 (Data Input Output 3) 4 (Data Input Output 4) 5 (Data Input Output 5) 6 (Data Input Output 6) 7 (Data Input Output 7) 8 (Data Input Output 8)	<ul style="list-style-type: none"> Besides data input, it is used for interface and device message input/output.
Handshake Bus	DAC (Data Valid) NRFD (Not Ready For Data) NDAC (Not Data Accepted)	<ul style="list-style-type: none"> Indicate that data on the data bus are valid. Indicate that the listener side is ready to receive. Indicate that the listener side has finished data reception.
Control Bus	ATN (Attention) REN (Remote Enable) IFC (Interface Clear) SRQ (Service Request) EOI (End of Identify)	<ul style="list-style-type: none"> Indicate whether the signal on the data bus carries data or an interface of device message. Switch between the remote and local control modes. Used to reset the interface. Signal sent by the talker side to call the controller. Indicates the end of data.

5.2.6 Response of Interface Messages

- The meter is capable of responding to the following messages.

Interface Message	Response
GTL (Go To Local)	<ul style="list-style-type: none"> Only addressed devices that receive this command are set to local mode. Cancel the remote control mode, making front panel switches operative.

5.2.7 Bus Driver

- Specifications of the meter bus driver are shown in the table below.

DIO 1 -- 8 SRQ NRFD NDAC	Open collector
EOI REN DAV IFC ATN	3 states

5.2.8 Command Error Message

Error Message	Name	Description
1	COMMAND	Command error
2	PARAMETER	Parameter error
4	NUMBER	Parameter over high/low limit
5	CONTINUE	The current measurement mode is under INT status but gives INT: IMM command.
6	TALK	Return character too long (250)
11	TYPE	Some commands are only suitable for the LCR 11025 but they aren't for the LCR 11022.
12	SENSE	No the function of power-on transformer measurement but gives the command of transformer measurement

5.3 RS-232 Interface Specification (Option)

5.3.1 Interface Specification

The standard RS-232 interface, the setting values are as follows.

Baud Rate: 9600 / 19200 / 28800 / 38400 / 57600
 Parity: NONE
 Flow Control: Hardware
 Transfer Bit: 1 start bit + 8 data bits + 1 stop bit
 Query command uses Q and A method.

5.3.2 RS-232 Interface Connector

The RS232 connector in the instrument is a 9-pin female connector.

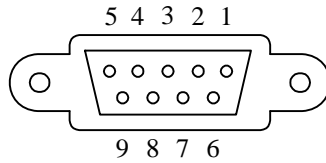

5.3.3 RS-232 Signal Cable and Pin Table

Pin	Name	Description
2	/TxD	Transmit Data
3	/RxD	Receive Data
5	GND	Ground
7	CTS	Clear to send
8	RTS	Request to send

⚡ CAUTION : The RS-232 and PC applying the same system power voltage are recommended as the meter connecting with PC, it avoid burning down the meter or component inside interface on PC terminal.

5.4 Command Description

5.4.1 Command Configuration

Command is with tree configuration level. All of 11022 related commands can see totally from the following figure.

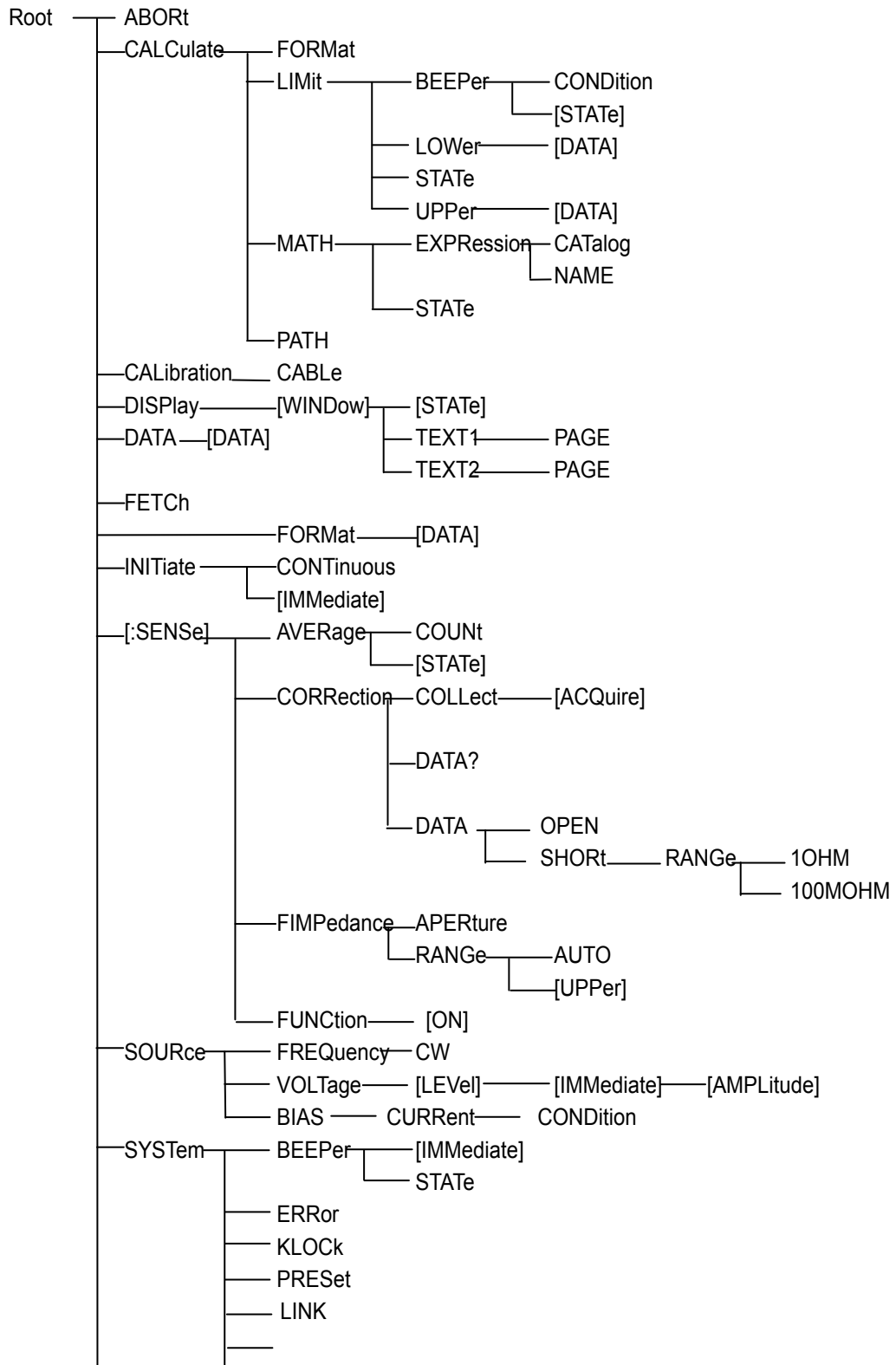

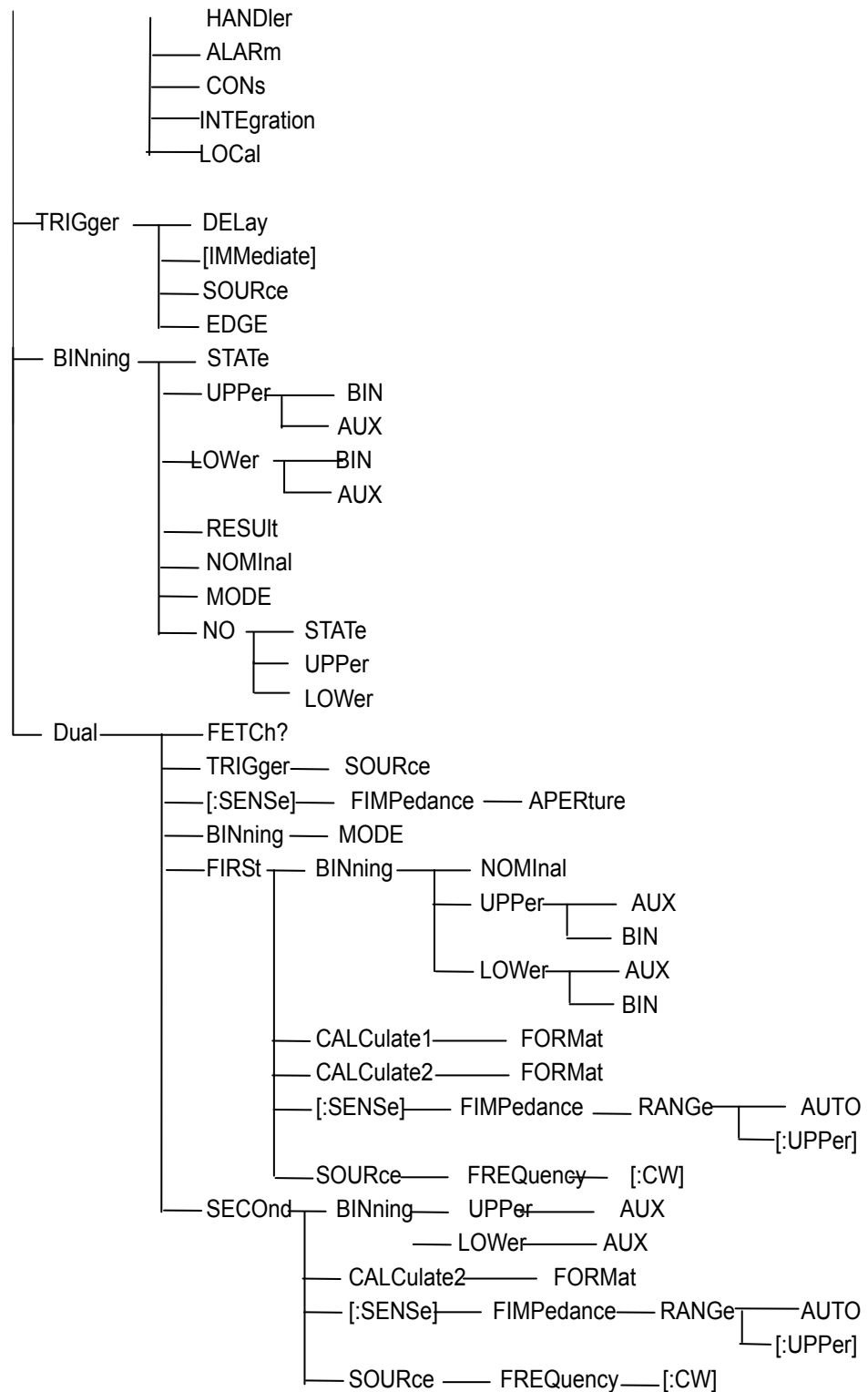

5.4.2 Description for Command Configuration

Tree configuration the top command is Root. There are six levels from the top level to the bottom level. If want to reach a certain level command, have to follow specific path then can reach it.

For example:

:CALCulate:MATH:EXPRession:NAME

Then can get NAME command correctly.

Moreover, if send (Example: NAME and CATalog) two commands simultaneously. Be able to use the following method make the instruction more easily and clearly.

:CALCulate : MATH: EXPRession:NAME;CATalog

Its' meaning is the same as the following two instructions. Isn't it more briefly?

:CALCulate:MATH:EXPRession:NAME
:CALCulate:MATH:EXPRession:CATalog

The commands need using colon (:) to separate between level and level. The first colon of every line signals are all point to Root. Another one need to pay attention is that two commands in one line signal need use semicolon (;) to separate it. For example:

:CALCulate:MATH:EXPRession:NAME;;SOURce:FREQUency:CW

Its' meaning is the same as the following two commands.

:CALCulate:MATH:EXPRession:NAME
:SOURce:FREQUency:CW

The first colon after semicolon is point to Root. If the commands are able to set and query, when sets only need to add parameter after command. When query only need to add “?” after command. If the frequency is set on 1kHz, the command is:

SOURce:FREQUency[:CW] 1kHz

If need to query, the command is: SOURce : FREQUency[:CW] ?

Moreover, the lowercase letters and [] parts in command can be omitted.

For example:

:SOURce:FREQUency[:CW]; also can write as

:SOUR:FREQ;

5.4.3 Command Syntax

(1) Common command syntax

The commands have General Command (as the last section listed) and Common Command. The general command with tree configuration level. And the common command doesn't with such configuration. Whatever in which level can be send directly by the following format.

* RST

(2) Do not distinguish capital and lowercase letter.

- (3) Before the first parameter in every command need a blank character.
To end character
To end character has three kinds: [CARRIAGE RETURN] (0Dh), [NEW LINE] (0Ah)
and [CARRIAGE RETURN] (0Dh) + [NEW LINE] (0Ah)

5.4.4 Common Command

- (1) *CLS
It clears the status Byte Register.
- (2) *ESE
It sets the Standard Event Status Enable Register.
- (3) *ESE?
It queries start bit in register.
- (4) *ESR?
It queries the contents of the Standard Event Status Register.
- (5) *IDN?
It queries identification string which consists of four fields. (Separated by comma)
- (6) *OPC
When all undetermined operations are completed, notify the 11022 Standard Event Status Register to set bit 0.
- (7) *OPC?
Put ASCII character 1 into output queue when all undetermined operations are completed to notify 11022.
- (8) *RCL
Recall setting parameter
- (9) *RST
It sets the 11022 to return to preset status.
- (10) *SAV
It saves setting parameter.
- (11) *SRE
It sets start bit in register.
- (12) *SRE?
It queries the content of the Status Byte Enable Register.
- (13) *TRG
It triggers the 11022 when the trigger mode is set to bus trigger.
- (14) *TST?
It performs self-test and returns test result of error total value. If there is no error the 11022 returns ϕ .

RAM1	1
RAM2	2
EEPROM	4
FPGA	8
Calibration Data	16

Main Board Test	32
Key Control	64

(15) *STB

It queries the contents of the Status Bit Register.

5.4.5 Command Description

ABORt Command

(1) Command: ABORt

Parameter: None

Return: None

Function: It terminates processing trigger system immediately, that is say to reset trigger system.

BINning Command Set

(1) Command: BINning: MODE {ABS|PCNT}

Parameter: {ABS(absolute value) | PCNT(%)}

Return: {ABS(absolute value) | PCNT(%)}

Function: It sets MODE to absolute value or percentage.

(2) Command: BINning : UPPer : BIN{1~8}

Parameter: {?| , <number> (NR3 mode)}

Return: {The upper limit value of each BINs}

Function: It sets the upper limit value of each BINs. When BINning: MODE ABS, it is the absolute value of inputted upper limit. When BINning: MODE PCNT, it is the percentage of inputted upper limit.

(3) Command: BINning : UPPer : AUX

Parameter: {The upper limit value (NR3) of secondary parameter B}

Return: {The upper value (NR3) of secondary parameter B}

Function: It sets AUX-HI value of BINNING, that is the upper limit value of measurement parameter B.

(4) Command: BINning : LOWer : BIN{1~8}

Parameter: {?| , <number> (NR3 mode)}

Return: {The lower limit value of each BINs}

Function: It sets the lower limit value of each BINs. When BINning: MODE ABS, it is the absolute value of inputted lower limit. When BINning: MODE PCNT, it is the percentage of inputted lower limit.

(5) Command: BINning : LOWer : AUX

Parameter: {The lower limit value (NR3) of secondary parameter B}

Return: {The lower limit value (NR3) of secondary parameter B}

Function: It sets AUX-LO value of BINNING, that is the lower limit value of measurement secondary parameter B.

(6) Command: BINning : NOMInal

Parameter: {The nominal value (NR3) of primary parameter A}

Return: {The nominal value (NR3) of primary parameter A}

Function: It sets NOMINAL value of BINNING, that is the nominal value of measurement primary parameter A.

- (7) Command: BINning: NO: STATE
 Parameter: {ON(1) | OFF(0)}
 Return: {1 | 0}
 Function: It sets if BIN NO>9 function in SYSTEM CONFIG is enabled.
- (8) Command: BINning: NO
 Parameter: {1~99}
 Return: {1~99}
 Function: It sets BIN NO when BIN NO>9 function in SYSTEM CONFIG is enabled.
- (9) Command: BINning: NO: UPPER
 Parameter: {The upper limit value (NR3) of BIN NO}
 Return: {The upper limit value (NR3) of BIN NO}
 Function: It sets the upper limit value of BIN NO when BIN NO>9 function in SYSTEM CONFIG is enabled.
- (10) Command: BINning: NO: LOWER
 Parameter: {The lower limit value (NR3) of BIN NO}
 Return: {The lower limit value (NR3) of BIN NO}
 Function: It sets the lower limit value of BIN NO when BIN NO>9 function in SYSTEM CONFIG is enabled.
- (11) Command: BINning : STATE
 Parameter: {ON(1) | OFF(0)}
 Return: {1 | 0}
 Function: It sets if BINNING open or not.
- (12) Command: BINning : RESULT
 Parameter: None
 Return: {The result of BINNING (+0 ~ +9)}
 {The result of BINNING (+0 ~ +100)} when BIN NO>9 function in SYSTEM CONFIG is enabled.
 Function: It queries the result of BINNING, if BINNING is OFF or sequence result is 0, output +0. If the sequence result is OUT, output +9. When BIN NO>9 function in SYSTEM CONFIG is enabled. If BINNING is OFF to output +0 and sequence result is 1 to output +1 as well as sequence result is OUT to output +100.

CALCulate Command Set

- (1) Command: CALCulate1:FORMat
 Parameter : {REAL|MLINear|CP|CS|LP|LS|ZS|RS|RP}
 Return: {REAL|MLINear|CP|CS|LP|LS}
 Function: It sets or queries the current measurement master parameter.
 Description:
- | | |
|---------|--------------------------------|
| REAL | Impedance real |
| MLINear | Impedance absolute value |
| CP | Equivalent parallel capacity |
| CS | Equivalent series capacity |
| LP | Equivalent parallel induction |
| LS | Equivalent series induction |
| ZS | Equivalent series impedance |
| RS | Equivalent series resistance |
| RP | Equivalent parallel resistance |

(2) Command: CALCulate2:FORMat

Parameter: {IMAGinary|PHASe|D|Q|REAL|RS|XS|LP|INV}

Return: {PHASe|D|Q|REAL|MLINear|LP|INV}

Function: It sets or queries the current measurement secondary parameter.

Description: IMAGinary Impedance imaginary
 PHASe Phase
 D Dissipation factor
 Q Quality factor
 REAL Impedance real
 RS Equivalent series resistance
 XS Imaginary series equivalent value
 MLINear Absolute value of impedance

Parameter	SENS: FUNC: ON	CALC1: FORM	CALC2: FORM
Z - θ R - X	"FIMPedance"	MLINear REAL	PHASe IMAGinary
Cp - D Cp - Q	"FADMittance"	CS	D QRp
Cs - D Cs - Q Cs - Rs	"FIMPedance"	CS	D Q REAL
Lp - D Lp - Q Lp - Rs	"FADMittance"	LP	D Q REAL

(3) Command: CALCulate{1|2}:LIMit:BEEPer:CONDition

Parameter: {FAIL|PASS}

Return: None

Function: Buzzer output definition.

Description: FAIL When the comparison result is FAIL buzzer action
 PASS When the comparison result is PASS buzzer action

(4) Command: CALCulate{1|2}:LIMit:BEEPer

Parameter: {ON(1)|OFF(0)}

Return: {1|0}

Function: It sets or queries whether buzzer is action or not.

Description: ON(1) Turn on buzzer.
 OFF(0) Turn off buzzer.

(5) Command: CALCulate{1|2}:LIMit:LOWer[:DATA]

Parameter: {The low limit value | MAXimum | MINimum}

Return: The low limit value, the format is <NR3>

Function: It sets or queries the low limit value.

Description: The low limit value needs between $-9.999E14 \sim 9.999E14$
 Give the command of MAXimum (9.999E14) or MINimum (-9.999E14) directly.

(6) Command: CALCulate{1|2}:LIMit:STATe

Parameter: {ON(1)|OFF(0)}

Return: {1|0}

Function: It sets or queries whether the comparison function is action or not.

Description: ON(1) Turn on comparison function
 OFF(0) Turn off comparison function

(7) Command: CALCulate{1|2}:LIMit:UPPer[:DATA]
 Parameter: {The high limit value | MAXimum | MINimum
 Return: The high limit value, the format is<NR3>
 Function: It sets or queries the high limit value.
 Description: The high limit value needs between $-9.999E14 \sim 9.999E14$
 Give the command of MAXimum (9.999E14) or MINimum (-9.999E14)
 directly.

(8) Command: CALCulate{1|2}:MATH:EXPRession:CATalog
 Parameter: None
 Return: Bias absolute value(DEV) or percentage(PCNT).
 Function: Return the parameter which can use with CALCulate{1|2}:MATH:
 EXPRession:NAME command.

(9) Command: CALCulate{1|2}:MATH:EXPRession:NAME
 Parameter: {DEV|PCNT}
 Return: {DEV|PCNT}
 Function: It sets or queries numerical represent method

(10) Command: CALCulate{1|2}:MATH:STATe
 Parameter: {ON(1)|OFF(0)}
 Return: {1|0}
 Function: It sets or queries CALCulate {1|2}:MATH:EXPRession:NAME definition
 operation management is action or not.
 Description: ON(1) Operation management action.
 OFF(0) Operation management do not action.

(11) Command: CALCulate{1|2}:PATH?
 Parameter: None
 Return: FORM, MATH, LIM
 Function: According to the sequence of performing CALCulate subsystem return
 CALCulate subsystem.

(12) Command: CALCulate{3|4}:MATH:STATe
 Parameter: {ON(1)|OFF(0)}
 Return: {1|0}
 Function: It sets or queries whether turn on Vm/Im function.
 Description: CALCulate3 Set current (Im)
 CALCulate4 Set voltage (Vm)
 ON(1) Turn on
 OFF(0) Turn off

CALibration Command

(1) Command: CALibration : CABLE
 Parameter: {0 | 1 | 2 | 4}
 Return: {0 | 1 | 2 | 4}
 Function: Select length of test cable.

DATA Command Set

(1) Command: DATA [:DATA] REF{1 | 2},

Parameter: {Primary, secondary parameter the nominal value in COMPARE (reference value) (NR3)}

Return: None

Function: It sets primary, secondary parameter the nominal value in COMPARE mode.
If the nominal value of primary parameter set on 100, command is DATA [:DATA] REF1, 100;

(2) Command: DATA [:DATA]?

Parameter: {REF1 | REF2 | IMON | VMON}

Return: {Query data (NR3)}

Function: It queries REF1 (the nominal value of COMPARE in primary parameter)
REF2 (the nominal value of COMPARE in secondary parameter)
IMON (measuring current value)
VMON (measuring voltage value)

When Im/Vm Display function is OFF, return value of IMON, VMON is 0.

DISPlay Command Set

(1) Command: DISPlay[:WINDow][:STATe]

Parameter: {ON(1)|OFF(0)}

Return: {1|0}

Function: It sets or queries LCD display is turned-on or turned-off status.

(2) Command: DISPlay[:WINDow]:TEXT1:PAGE

Parameter: {1|2}

Return: {1|2}

Function: It sets or queries display screen.

Description: 1 Measuring screen
2 Comparison screen

(3) Command: DISPlay[:WINDow]:TEXT2:PAGE

Parameter: {1|2|3}

Return: {0|1|2}

Function: It sets or queries page of measuring screen.

Description: 1. Show the first page of measuring screen (test frequency, level and parameter).
2. Show the second page of measuring screen (file, average time and trigger mode).
3. Show the third page of measuring screen (DC bias, binning and comparison sets).

DUAL Command Set

Note : DUAL command set is only for dual frequency function screen that is entering this screen.

(1) Command: DUAL:FIRSt:CALCulate1:FORMat

Parameter: {REAL|MLINear|CP|CS|LP|LS|ZS|RS|RP}

Return: {REAL|MLINear|CP|CS|LP|LS|ZS|RS|RP}

Function: It sets or queries the 1st measurement primary parameter in dual frequency function.

Description: REAL	Impedance real
MLINear	Impedance absolute value
CP	Equivalent parallel capacitance

CS	Equivalent series capacitance
LP	Equivalent parallel inductance
LS	Equivalent series inductance
ZS	Equivalent series impedance
RS	Equivalent series resistance
RP	Equivalent parallel resistance

- (2) Command: DUAL:FIRSt:CALCulate2:FORMat
 Parameter: {IMAGinary|PHASe|D|Q|REAL|RS|XS}
 Return: {IMAGinary|PHASe|D|Q|REAL|RS|XS}
 Function: It sets or queries the 1st measurement secondary parameter in dual frequency function.

Description: IMAGinary	Impedance imaginary
PHASe	Phase
D	Dissipation factor
Q	Quality factor
REAL	Impedance real
RS	Equivalent series resistance
XS	Imaginary series equivalent value

- (3) Command: DUAL:SECOnd:CALCulate2:FORMat
 Parameter: {IMAGinary|PHASe|D|Q|REAL|RS|XS}
 Return: {IMAGinary|PHASe|D|Q|REAL|RS|XS}
 Function: It sets or queries the 2nd measurement secondary parameter in dual frequency function.

Description: IMAGinary	Impedance imaginary
PHASe	Phase
D	Dissipation factor
Q	Quality factor
REAL	Impedance real
RS	Equivalent series resistance
XS	Imaginary series equivalent value

- (4) Command: DUAL:FIRSt[:SENSe]:FIMPedance:RANGe:AUTO
 Parameter: {ON(1)|OFF(0)}
 Return: {1|0}
 Function: The 1st measurement setting or query in dual frequency function if auto range selection mode is enabled.

- (5) Command: DUAL:FIRSt[:SENSe]:FIMPedance:RANGe[:UPPer]
 Parameter: {Measurement range value |UP|DOWN}
 Unit: [MOHM | KOHM | OHM | MAOHM], if the unit isn't given then it will be defined as OHM.
 Return: {Measurement range value}, the format is < NR3 >
 Function: The 1st measurement setting or query measurement range in dual frequency function.

Description: UP	Move to the previous range
DOWN	Move to the next range
Range values contain 8 ranges of 1M, 100k, 10k, 1k, 100, 10, 1 and 0.1 ohm.	

- (6) Command: DUAL: SECOnd [:SENSe]:FIMPedance:RANGe:AUTO
 Parameter: {ON(1)|OFF(0)}
 Return: {1|0}

- Function: The 2nd measurement setting or query in dual frequency function if auto range selection mode is enabled.
- (7) Command: DUAL:SECOnd[:SENSE]:FIMPedance:RANGe[:UPPer]
 Parameter: {Measurement range value |UP|DOWN}
 Unit: [MOHM | KOHM | OHM | MAOHM], if the unit isn't given then it will be defined as OHM.
 Return: {Measurement range value}, the format is < NR3 >
 Function: The 2nd measurement setting or query measurement range in dual frequency function.
 Description: UP Move to the previous range
 DOWN Move to the next range
 Range values contain 8 ranges of 1M, 100k, 10k, 1k, 100, 10, 1 and 0.1 ohm.
- (8) Command: DUAL:FIRSt:SOURce:FREQUency[:CW]
 Parameter: Test frequency
 Unit: [HZ 1kHz], if the unit isn't given then it will be defined as HZ.
 Return: Test frequency, the format is < NR3 >.
 Function: The 1st measurement setting or query test frequency currently in dual frequency function.
 Description: Test frequencies consist of 50, 60, 100, 120, 1k, 10k, 20k, 40k, 50k, and 100kHz.
- (9) Command: DUAL:SECOnd:SOURce:FREQUency[:CW]
 Parameter: Test frequency
 Unit: [HZ 1kHz], if the unit isn't given then it will be defined as HZ.
 Return: Test frequency, the format is < NR3 >.
 Function: The 2nd measurement setting or query test frequency currently in dual frequency function.
 Description: Test frequencies consist of 50, 60, 100, 120, 1k, 10k, 20k, 40k, 50k and 100kHz.
- (10) Command: DUAL:BINning:MODE {ABS|PCNT}
 Parameter: {Absolute value (ABS) | PCNT (%)}
 Return: {Absolute value (ABS) | PCNT(%)}
 Function: It sets MODE to ABS or PCNT in dual frequency function.
- (11) Command: DUAL:FIRSt:BINning:NOMInal
 Parameter: {Nominal value (NR3) of the 1st measurement primary parameter.}
 Return: {Nominal value (NR3) of the 1st measurement primary parameter.}
 Function: The nominal value of 1st measurement setting Binning in dual frequency function, *i.e.* the nominal value of measurement primary parameter.
- (12) Command: DUAL:FIRSt:BINning:UPPer:AUX
 Parameter: {High limit (NR3) of the 1st measurement secondary parameter.}
 Return: {High limit (NR3) of the 1st measurement secondary parameter.}
 Function: The AUX-HI value of 1st measurement setting Binning in dual frequency function, *i.e.* the high limit value of measurement secondary parameter.
- (13) Command: DUAL:SECOnd:BINning:UPPer:AUX
 Parameter: {High limit (NR3) of the 2nd measurement secondary parameter.}
 Return: {High limit (NR3) of the 2nd measurement secondary parameter.}
 Function: The AUX-HI value of 2nd measurement setting Binning in dual frequency

function, *i.e.* the high limit value of measurement secondary parameter.

(14)Command: DUAL:FIRSt:BINning:LOWer:AUX

Parameter: {Low limit (NR3) of the 1st measurement secondary parameter.}

Return: {Low limit (NR3) of the 1st measurement secondary parameter.}

Function: The AUX-LO value of 1st measurement setting Binning in dual frequency function, *i.e.* the low limit value of measurement secondary parameter.

(15)Command: DUAL:SECOnd:BINning:LOWer:AUX

Parameter: {Lower limit (NR3) of the 2nd measurement secondary parameter.}

Return: {Lower limit (NR3) of the 2nd measurement secondary parameter.}

Function: The AUX-LO value of 2nd measurement setting Binning in dual frequency function, *i.e.* the lower limit value of measurement secondary parameter.

(16)Command: DUAL:FIRSt:BINning:UPPer:BIN{1~4}

Parameter: {?| , <number> (NR3 mode)}

Return: {The various BINs high limit of the 1st measurement primary parameter.}

Function: The various BINs high limit of the 1st measurement primary parameter in dual frequency function. The command of DUAL:BINning:MODE ABS is for inputting the absolute value of high limit. The command of DUAL:BINning:MODE PCNT is for inputting the percentage value of high limit.

(17)Command: DUAL:FIRSt:BINning:LOWer:BIN{1~4}

Parameter: {?| , <number> (NR3 mode)}

Return: {The various BINs low limit of the 1st measurement primary parameter.}

Function: The various BINs low limit of the 1st measurement primary parameter in dual frequency function. The command of DUAL:BINning:MODE ABS is for inputting the absolute value of low limit. The command of DUAL:BINning:MODE PCNT is for inputting the percentage value of low limit.

(18)Command: DUAL:FEtCh?

Parameter: None

Return: <FIRST STATE>, <FIRST DAT1>, <FIRST DAT2>, <SECOND STATE>, <SECOND DAT2>, <FIRST BIN1>, <FIRST BIN2>, <SECOND BIN2>

Function: It fetches measurement result which INITiate command obtained.

Description:

< FIRST STATE >	First Measurement State
0	Normal
1	Overload (Range selected error)
2	DUT no contact
<FIRST DAT1>	First Measurement Primary Parameter Test Value
< FIRST DAT2>	First Measurement Secondary Parameter Test Value
<SECOND STATE>	Second Measurement State
0	Normal
1	Overload (Range selected error)
2	DUT no contact
<SECOND DAT2>	Second Measurement Primary Parameter Test Value
<FIRST BIN1>	First Measurement Primary Parameter BIN result
0	BIN OUT
1~4	BIN Number
<FIRST BIN2>	First Measurement Secondary Parameter BIN result
0	NOGO
1	GO
<SECOND BIN2>	Second Measurement Secondary Parameter BIN result

0	NOGO
1	GO

(19) Command: DUAL: TRIGger: SOURce

Parameter: {BUS|EXTeRnal|INTeRnal|MANual}

Return: {BUS|EXTeRnal|INTeRnal|MANual}

Function: It sets or queries trigger mode currently in dual frequency function.

Description: BUS	Bus trigger
EXTeRnal	External trigger
INTeRnal	Internal trigger
MANual	Manual trigger

(20) Command: DUAL [:SENSe]:FIMPedance:APERture

Parameter: 0.025 (Fast), 0.065 (Medium), 0.500 (Slow)

Return: 0.025 (Fast), 0.065 (Medium), 0.500 (Slow)

Function: It sets or queries measurement speed currently in dual frequency function.

FETCh? Command

(1) Command: FETCh?

Parameter: None

Return: <STATE>, <DAT1>, <DAT2>, <CMP1>, <CMP2>

Function: It fetches measurement result which INITiate command obtained.

Description:

<STATE> Measuring State

0	Normal
1	Overload (Range selected error)
2	DUT no contact

<DAT1> Primary parameter test value

<DAT2> Secondary parameter test value

When comparator is opening, there are outputs as follows.

<CMP1> Primary parameter comparison result

<CMP2> Secondary parameter comparison result

0	Without secondary parameter
1	Test value within the range
2	Test value too high
4	Test value too low

When BINNING is opening, there are outputs as follows.

<BIN> Sequence result

0	B parameter Fail
1~8	A, B parameters Pass
9	A parameter Fail

When BIN>9 is opening, there are outputs as follows.

<BIN>9> Sequence result

0	B parameter Fail
1~99	A, B parameters Pass
100	A parameter Fail

FORMat Command

- (1) Command: FORMat[:DATA]
Parameter: {ASCIi}
Return: ASK
Function: It sets or queries the data format of transmission numeral.

INITiate Command Set

- (1) Command: INITiate[:IMMEDIATE]
Parameter: None
Return: None
Function: All sequences escape from idle status and enter initial status.
- (2) Command: INITiate:CONTInuous
Parameter: {ON(1)|OFF(0)}
Return: {1|0}
Function: It sets or queries whether initial trigger system sequentially.
Description: 0 No sequential initial trigger system
1 With sequential initial trigger system

[:SENSe] Command Set

- (1) Command: [:SENSe]:AVERAge:COUNT
Parameter: {1 ~ 256}
Return: {1 ~ 256}
Function: It sets or queries average time.
- (2) Command: [:SENSe]:CORRection:COLLect[:ACQuire]:STANdard
Parameter: {1|2|3|4}
Return: None
Function: It performs OPEN, SHORT correction procedure.
Description: 1 It performs OPEN correction procedure.
2 It performs SHORT correction procedure.
- (3) Command: [:SENSe]:CORRection:DATA?STANdard
Parameter: {1|2}
Return: Two correction values, the format is <NR3>
Function: It queries correction value.
STANdard 1 is the current range OPEN correction value, that is G, B.
STANdard 2 is the current range SHORT correction value, that is R, X.
- (4) Command: [:SENSe]:CORRection:DATA:OPEN
[:SENSe]:CORRection:DATA:OPEN?
Parameter: None
Return: OPEN correction numeral, the format is < NR3 >
Function: It sets or queries OPEN correction value, that is G, B.
- (5) Command: [:SENSe]:CORRection:DATA:SHORT
[:SENSe]:CORRection:DATA:SHORT?
Parameter: None
Return: SHORT correction value, the format is < NR3 >
Function: It sets or queries correction value of SHORT $\geq 10\Omega$, that is R, X
- (6) Command: [:SENSe]:CORRection:DATA:SHORT:RANGe:1OHM

- [:SENSe]:CORRection:DATA:SHORT:RANGe:1OHM?
 Parameter: None
 Return: SHORT correction value of RANGE 1Ω, the format is < NR3 >
 Function: It sets or queries SHORT correction value of RANGE 1Ω, that is R, X
- (7) Command: [:SENSe]:CORRection:DATA:SHORT:RANGe:100MOHM
 [:SENSe]:CORRection:DATA:SHORT:RANGe:100MOHM?
 Parameter: None
 Return: SHORT correction value of RANGE 100mΩ, the format is < NR3 >
 Function: It sets or queries SHORT correction value of RANGE 100mΩ, that is R, X
- (8) Command: [:SENSe]:FIMPedance:APERture
 Parameter: 0.025 (Fast), 0.065 (Medium), 0.500 (Slow)
 Return: 0.025 (Fast), 0.065 (Medium), 0.500 (Slow)
 Function: It sets or queries measuring speed.
- (9) Command: [:SENSe]:FIMPedance:RANGe:AUTO
 Parameter: {ON(1)|OFF(0)}
 Return: {1|0}
 Function: It sets or queries if turn on auto range selection mode.
- (10) Command: [:SENSe]:FIMPedance:RANGe[:UPPer]
 Parameter: {Measuring range value|UP|DOWN}
 Unit: [MOHM|kOHM|OHM|MAOHM]
 If there is no unit is given then auto defines OHM.
 Return: {Measuring file value}, the format is <NR3>
 Function: It sets or queries the measurement range.
 Description: UP To the previous range
 DOWN To the next range
 Range values 1M, 300k, 100k, 30k, 10k, 3k, 1k, 300, 100, 10, 1 and
 0.1 ohm are 12 ranges in total.
- (11) Command: [:SENSe]:FUNction[:ON]
 Parameter: {FIMPedance|FADMittance}
 Return: {FIMPEDANCE|FADMITTANCE}
 Description: FIMPedance is for equivalent series mode.
 FADMittance is for equivalent parallel mode.
 Function: It sets or queries circuit measurement equivalent mode.

SOURce Command Set

- (1) Command: SOURce:FREQUency[:CW]
 Parameter: Test frequency.
 Unit: [HZ 1kHz], if there is no command unit then auto define HZ.
 Return: Test frequency, the format is <NR3>.
 Function: It sets or queries the present test frequency.
 Description: Test frequencies are 50, 60, 100, 120, 1k, 10k, 20k, 40k, 50k and 100kHz.
- (2) Command: SOURce:VOLTage[:LEVel][:IMMediate][:AMPLitude]
 Parameter: Test voltage
 Return: Test voltage, the format is <NR3>.
 Function: It sets or queries test voltage now.
 Description: Test voltage range is 0.01 ~ 1Vrms. Resolution is 10mV.

- (3) Command: SOURce:BIAS:CURRent:CONDition
Parameter: {ON(1)|OFF(0)}
Return: {1|0}
Function: It returns and sets the output condition of bias current source.
Description: ON(1) Enable bias current source output.
OFF(0) Disable bias current source output.
- (4) Command: SOURce:VOLTage[:LEVel][:IMMediate] :OFFSet:STATe
Parameter: {ON(1)|OFF(0)}
Return: {1|0}
Function: It sets if BIAS V function is enabled.
- (5) Command: SOURce:BIAS:CURRent
Parameter: Bias current value
Return: Bias current value, format is <NR3>
Function: It returns and sets bias current value.
Description: Be able to set the range of bias current value of a 1320 Bias Current Source 0-10A as 0.000A~10.000A. Be able to set the range of bias current value of a 1320 Bias Current Source 0-20A as 0.000A~20.000A. When a 1320 Bias Current Source 0-20A connects a 1320S, bias current value range can set is 0.000A ~ 40.000A. A 1320 Bias Current Source 0-20A can connect four 1320S maximumly, thus bias current value range is 0.000A ~ 100.000A.

STATus Command Set

- (1) Command: STATus: OPERation [: EVENT]?
Parameter: Event register status
Return: Register status, the format is <NR1>.
Function: It returns event register status of operation status group, and clear it after read event register.
- (2) Command: STATus: OPERation: CONDition?
Parameter: Condition register status
Return: Register status, the format is <NR1>.
Function: It returns condition register status of operation condition group, and don't clear it after read condition register.
- (3) Command: STATus: OPERation: ENABle
Parameter: Condition register status
Return: Register status, the format is <NR1>.
Function: It sets enable register status.

SYSTem Command Set

- (1) Command: SYSTem:BEEPPer[:IMMediate]
Parameter: None
Return: None
Function: Buzzer sound beep immediately.
- (2) Command: SYSTem:BEEPPer:STATe
Parameter: {ON(1)|OFF(0)|LARGe(2)}
Return: {1|0|2}
Function: It sets or queries whether buzzer is turned on or not.
OFF(0) – turn off buzzer
ON(1) – turn on buzzer (small)
LARGE(2) – turn on buzzer (large)

- (3) Command: SYSTem:ERRor?
Parameter: None
Return: It returns error message in queue, the fixed return is 0.

- (4) Command: SYSTem:KLOCK
Parameter: {ON(1)|OFF(0)}
Return: {1|0}
Function: It sets or queries whether 11022 key is locked or not.

- (5) Command: SYSTem:LOCAL
Parameter: None
Return: None
Function: Release REMOTE status. This command only support RS-232 communication interface (option). If REMOTE status is released when using GPIB communication interface, please see GTL command in 5.2.6 *Response of Interface Messages*.

- (6) Command: SYSTem:PRESet
Parameter: None
Return: None
Function: It sets the 11022 back ex-factory default status, but do not change key lock status.

- (7) Command: SYSTem:VERSion
Parameter: None
Return: The 11022 SCPI version corresponding value is Y.V, Y means Year, V means version.

- (8) Command: SYSTem : CONST
Parameter: {100/25 | 100 | 10C | 25}
Return: {100/25 OHM | 100 OHM | 10C OHM | 25 OHM}
Function: It sets output impedance mode. There are 100/25 Ω , 100 Ω , 10 Ω /CC, 25 Ω etc.

- (9) Command: SYSTem : INTEgration
Parameter: {1~8}
Return: {1~8}
Function: It calculates period selection function for deciding every sampling period when quick measurement. Range is 1~8.

- (10) Command: SYSTem : ALARm
Parameter: {PULSE | CONTinuous}
Return: {PULS | CONT}
Function: Select buzzer action is PULSE or CONTINUOUS when BINSORTING and COMPARE.

- (11) Command: SYSTem : HANDler
Parameter: {CLEAr | HOLD}
Return: {CLEA | HOLD}
Function: Select HANDLER MODE, please refer 4.3.1.

- (12) Command: SYSTem : LINK
Parameter: {ON(1) | OFF(0)}
Return: {1 | 0}

Function: It sets LINK1320 ON/OFF.

TRIGger Command Set

- (1) Command: TRIGger:DElAy
 Parameter: Trigger delay time
 Unit: [MS|S] if there is no command unit the auto define S.
 Return: Trigger delay time, the format is <NR3>.
 Function: It sets or queries trigger delay time, the range is 0 ~ 9999ms.
- (2) Command: TRIGger:[IMMediate]
 Parameter: None
 Return: None
 Function: Whatever the present measuring status, perform trigger measurement.
- (3) Command: TRIGger:SOURce
 Parameter: {BUS|EXTernal|INTernal|MANual}
 Return: {BUS|EXTernal|INTernal|MANual}
 Function: It sets or queries trigger mode now.
 Description: BUS BUS Trigger
 EXTernal External Trigger
 INTernal Internal Trigger
 MANual Manual Trigger
- (4) Command: TRIGger : EDGE
 Parameter: {FALLing | RISIng}
 Return: {FALL | RISI}
 Function: It sets TRIGGER mode to EXTERNAL, is RISING or FALLING trigger.

5.4.6 Command Notices

- (1) When users give TRIGger command, 11022 measuring is activated. Meanwhile, if FETCh? command is given, for taking a period of the actual measurement time is needed then the measurement result fetched by FETCh? Command will be shown. The calculation of this period of measurement time is as the following:

Measurement Time= Trigger Delay+Average Time×Measurement Time of *Table 2-4*.

In the above formula:

“Measurement Time” is the spending time from giving TRIGger command to getting measurement result.

“Trigger Delay” is when 11022 received trigger action, how much delay time is needed then can to process measuring.

“Average Time” is the average time of measurement.

“Measurement Time of Table 2-4 is when the average time is 1 in *Table 2-4*, the spending time of different speed, frequency and measurement parameter.

Note : The range of this test condition is Hold.

For example, Trigger Delay time is set to 100ms, Average Time is twice, the speed is set to medium and the measured time Cs-D, thus the measurement time is 202ms. The calculation method is as the following.

Measurement Time= 100ms+ 2×51ms= 202ms

- (2) When users give TRIGger command, the sequential other setting commands (non FETCH ? commands) will be given. The program needs to write the function of time delay. This delay time is the measurement time of 11022, otherwise the part of sequential commands can't normal function. Take above item for example, it is needed to write 202ms delay time program to ensure the sequential commands are all normal functioning.

5.4.7 Format of Data Transfer

Numerical data uses ASCII byte, <NR1> (Integer format), <NR2> (Fixed decimal format), <NR3> (Floating point format) format processing transfer, separate by comma between data (IEEE-488.2 standard). The format description is as the following.

- (1) <NR1> format:

For example: 9000

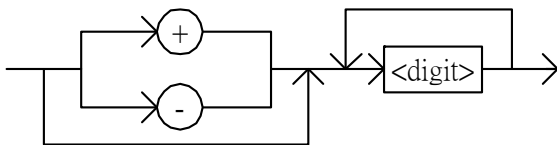

- (2) <NR2> format:

For example: 9000.0

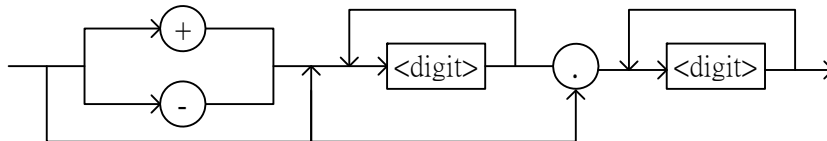

- (3) <NR3> format:

For example: 9.0E+3

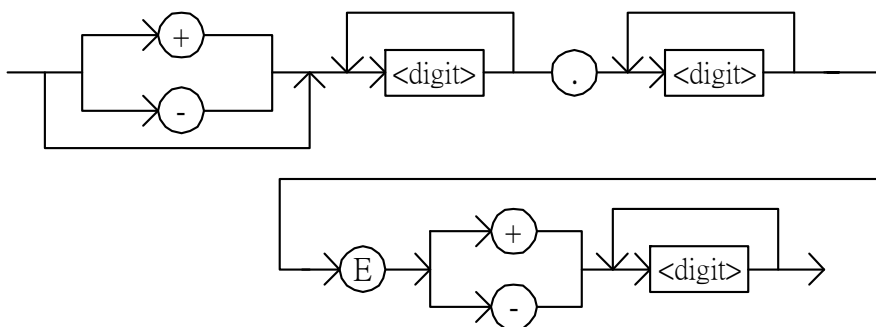

5.5 Disable Connection (Remote) Mode

To disable the GPIB connection mode, please enter the following keys: [F1], [F4], [SYSTEM SETUP]. If the instrument is currently in KEY LOCK mode, please enter the above keys again.

5.6 Status Reporting Structure

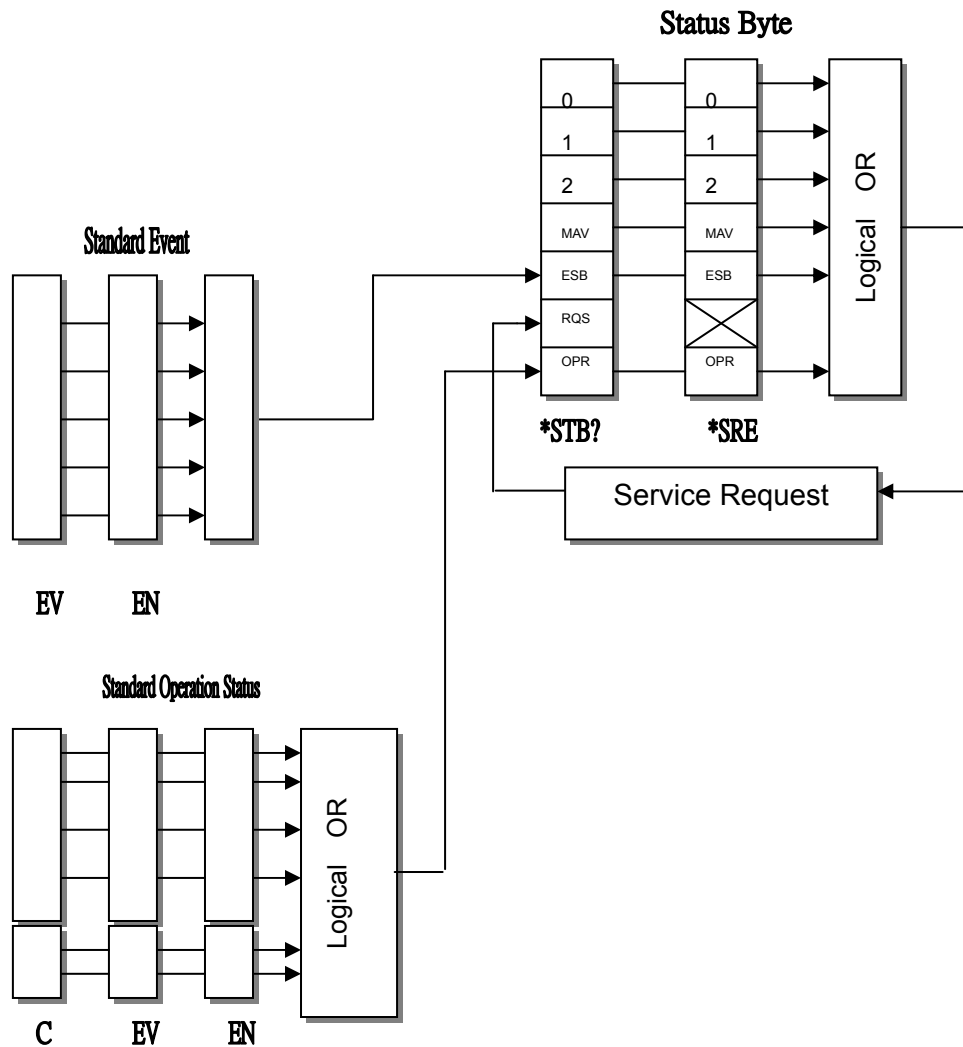

Figure 5-1 Status Reporting Structure

The 11022 LCR Meter can send an SRQ (Service Request) control signal when it requires the controller to perform a task. When the 11022 LCR Meter generates an SRQ, it also sets Bit 6 of the status Byte Register, RQS (Request Service) bit. Service Request Enable Register allows an operation programmer to select which summary messages in the Status Byte Register may cause service requests.

5.7 Status Byte Register

The Status Byte Register is composed of eight bits that summarize an overlaying status data structure. The Status Byte Register can be read using either *STB? Or SPOLL, which return a decimal expression of the contents of the register (equal to the sum of the total bit weights of all the bits set to "1").

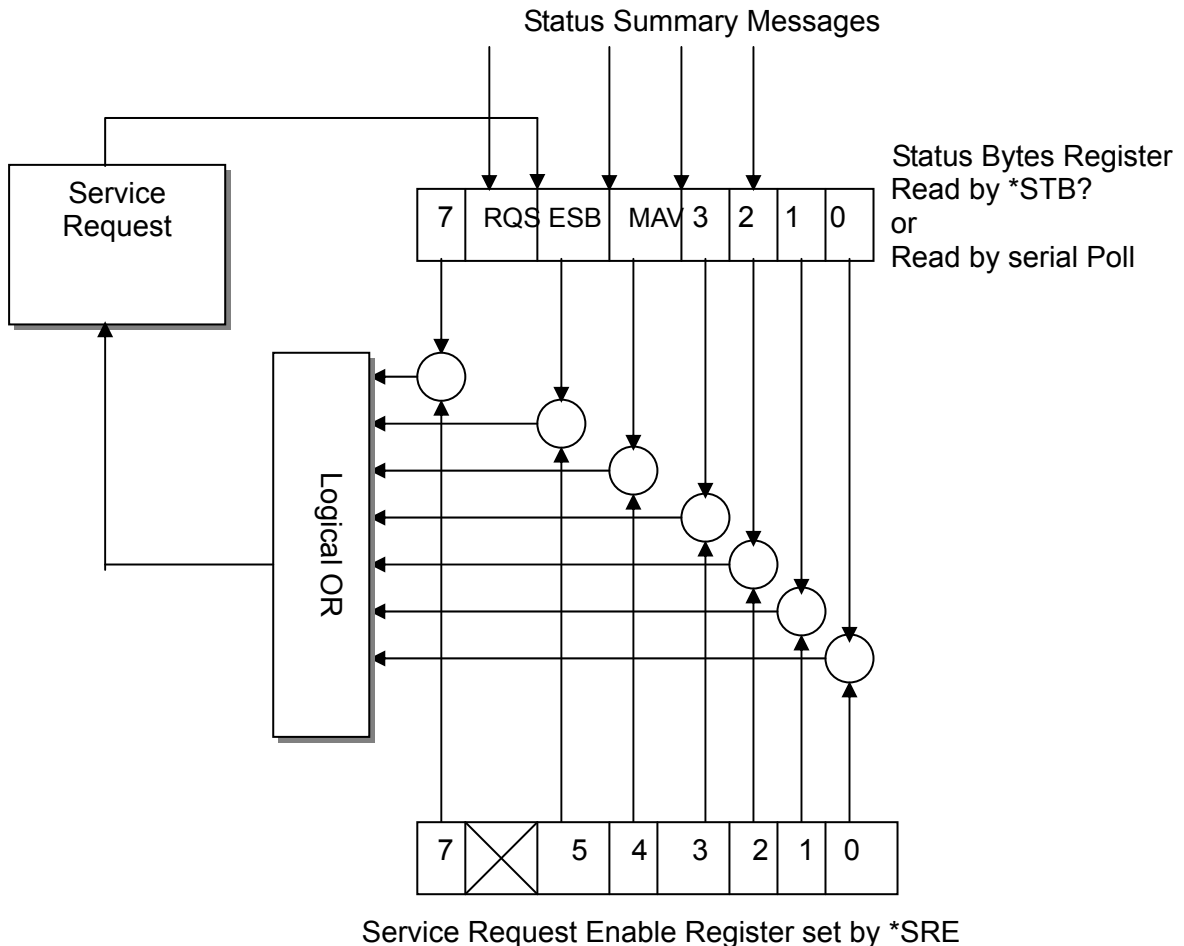

Figure 5-2 Status Byte Register

Bit No.	Bit Weight	Description
7	128	Operation Status Register Summary Bit
6	64	Request Service Bit – This bit is set when any enabled bit of the Status Byte Register has been set, which indicates 11022 LCR Meter has at least one reason for requesting service. SPOLL resets this bit.
5	32	Standard Event Status Register Summary Bit.
4	16	When 11022 measurement is completed, this bit will be set.
3~0		Always Zero (0)

Table 5-1 Status Byte Assignment

5.8 Standard Event Status Register

The Standard Event Status Register is frequently used and is one of the simple.

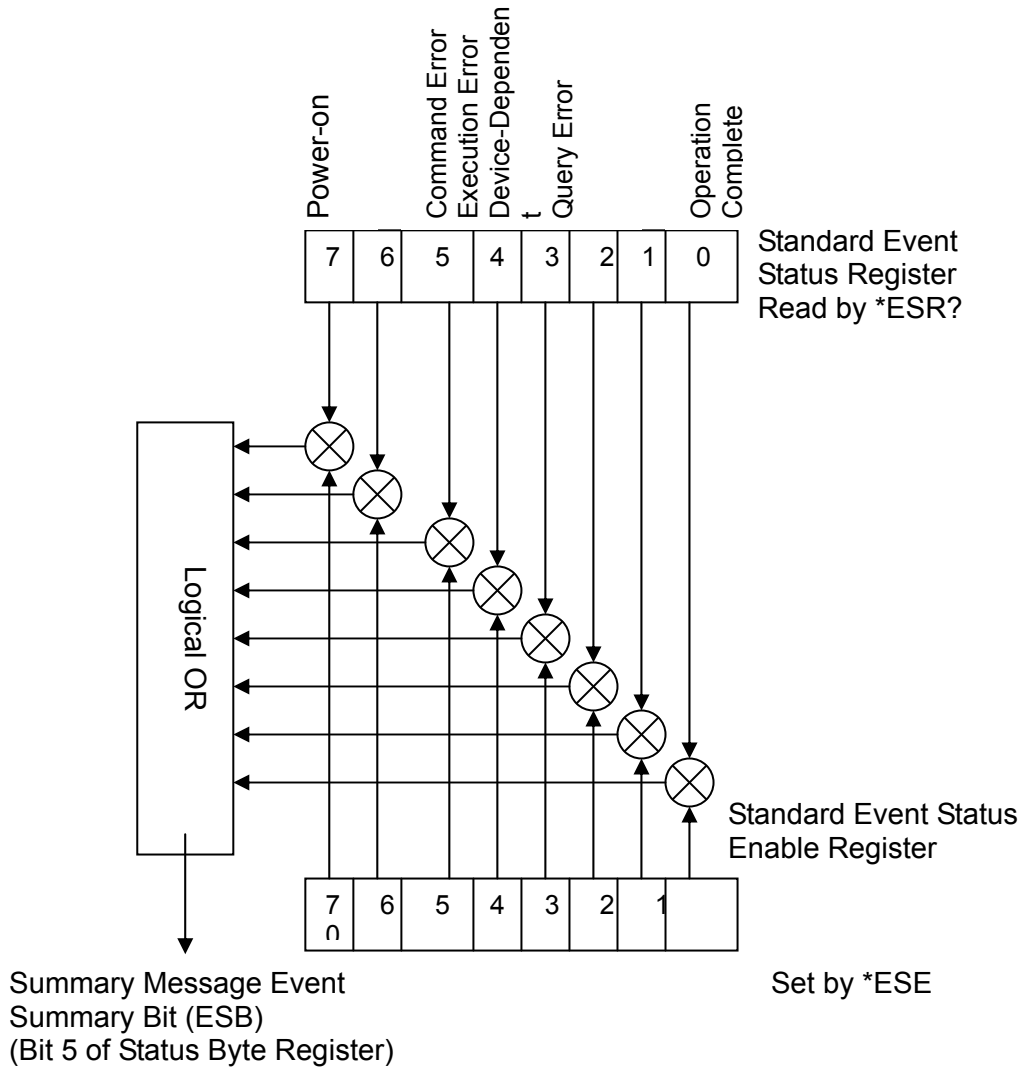

Figure 5-3 Standard Event Status Register

Bit No	Bit Weight	Description
7	128	Power on Bit – This bit is set when the 11022 LCR Meter has been turned OFF and then ON since the last time this register was read.
6		Always zero (0)
5	32	Command Error Bit- This bit is set if the following command errors occur. <ul style="list-style-type: none"> ● An IEEE 488.2 syntax error occurred. ● The 11022 LCR Meter received a Ground Execute Trigger inside a program message.
4	16	Always zero (0)
3	8	Always zero (0)
2	4	Always zero (0)
1		Always Zero (0)
0	1	Operation Complete Bit- This bit is set when the 11022 LCR Meter has completed all selected pending operation before sending the *OPC command.

Table 5-2 Standard Event Status Register Assignment

5.9 Standard Operation Status Group

The 11022 LCR Meter provides two Standard Operation Status groups - operation status register group and questionable status register group- which can be accessed using the STATus subsystem commands. As a beginner, you will rarely need to use this group. The individual bit assignments of these registers are given in “operation Status Register” and “Questionable Status Register” later in this section.

Each group includes a condition register, an event register and an enable register.

The condition register reflects the internal states of the 11022 LCR meter. (Reserved)

The event register's bits correspond to the condition register's bits. A transition filter reports an event to the event register, when a condition register bit changes from “1” to “0” for all bits except for bit no. 8 and 9. For bit number 8 & 9, the bit rule is changing from “0” to “1”.

The enable register enables the corresponding bit in the event register to set the status summary bit, bit 7 or bit 3 of the status Byte Register.

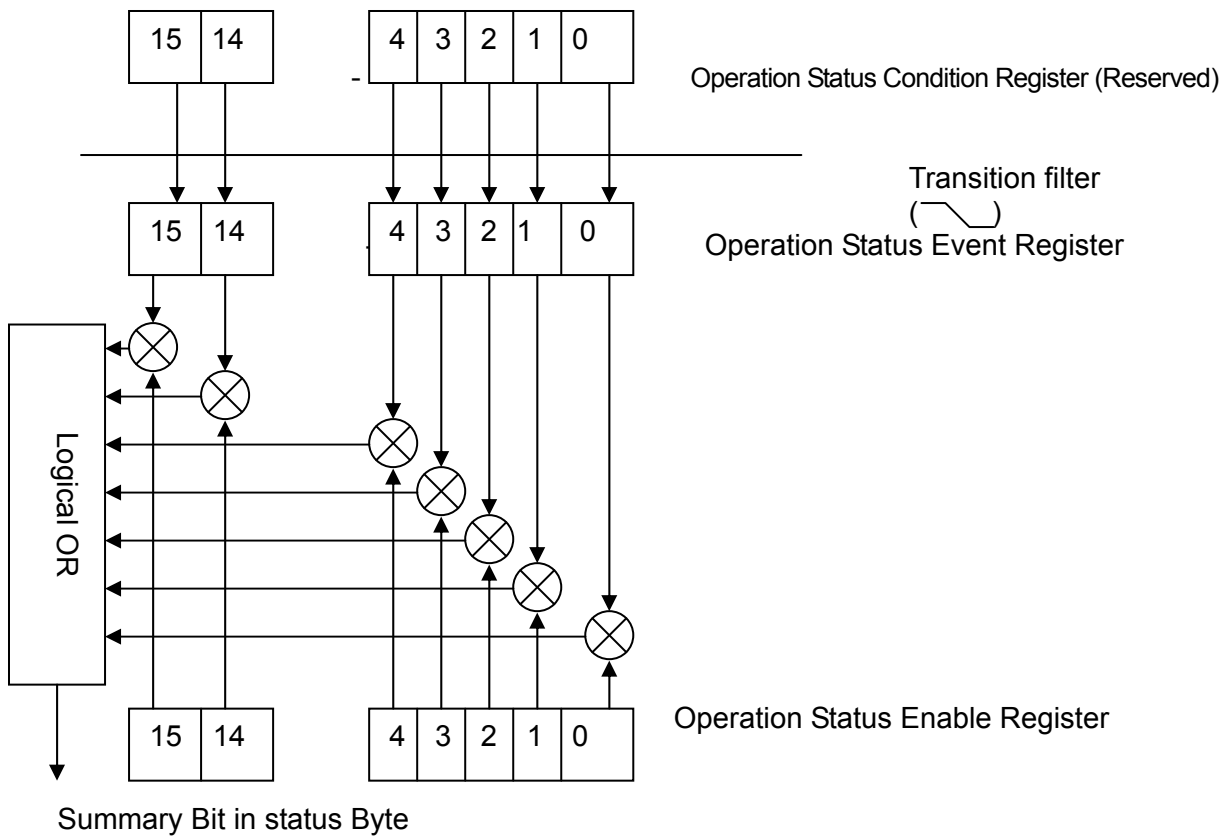

Figure 5-4 Standard Operation Status Group Structure

Bit No	Bit Weight	Description
10 – 15		Always zero (0)
6	64	Always zero (0)
5	32	Always zero (0)
4	16	Always zero (0)
3	8	Always zero (0)
2	4	Always zero (0)
1	2	Always zero (0)
0	1	Always zero (0)

Table 5-3 Operation Status Condition Register Assignment (Reserved)

Bit No	Bit Weight	Description
10 – 15		Always zero (0)
6	64	Always zero (0)
5	32	Always zero (0)
4	16	When 11022 measurement is completed, this bit will be set.
3	8	Always zero (0)
2	4	Always zero (0)
1	2	Always zero (0)
0	1	Always zero (0)

Table 5-4 Operation Status Event Register Assignment

6. Description of Handler Interface

Binning, Compare and Bias Compare in 11022 as well as LINK 1320(1320 Bias Current Source 0-10A and 1320 Bias current Source 0-20A) are all connected to external unit by Handler interface. There are connectors 50 Pin (Standard) and 24 Pin (Optional) in Binning, Compare and Bias Compare, LINK 1320 only has 50 Pin connector. The pin descriptions are as follows. The external trigger signal (/EXT), analog sampling end signal (ACQ) and end of test signal (EOT) between them have timing relation and will be described in *section 6.5*.

6.1 Description for Binning Handler Interface Pin

6.1.1 50 Pin

Pin	Name	Description
1-2	VEXT	External DC voltage, acceptable voltage range is 5V ~ 24V.
3-18	X	N.C
19	/EXT	External trigger
20-21	VEXT	External DC voltage acceptable voltage range is 5V ~ 24V.
22-23	X	N.C
24-25	VINT	Internal DC voltage +5V
26-27	COM	COMMON
28	BIN 8	BIN 8, primary parameter test value within BIN 8 setting range
29	BIN 3	BIN 3, primary parameter test value within BIN 3 setting range
30	BIN 7	BIN 7, primary parameter test value within BIN 7 setting range
31	BIN 5	BIN 5, primary parameter test value within BIN 5 setting range
32	BIN 2	BIN 2, primary parameter test value within BIN 2 setting range
33	BIN 6	BIN 6, primary parameter test value within BIN 6 setting range
34	BIN 0	BIN 0, secondary parameter test value over high, low limit setting value
35	BIN 1	BIN 1, primary parameter test value within BIN 1 setting range
36	BIN 4	BIN 4, primary parameter test value within BIN 4 setting range
37	X	N.C
38	BIN OUT	BIN OUT, primary parameter test value not in all sets specifications
39-42	X	N.C
43	ACQ	Analog sampling end, can moving next DUT to 11022 test terminal.
44	EOT	End of test
45-46	COM	COMMON
47-48	X	N.C
49-50	GND	Connect with cover

Note

- ▮ Primary parameters are L, C, R, and Z
- ▮ Secondary parameters are Q, D, Xs, ESR, and θ

6.1.2 24 Pin

Pin	Name	Description
1	/EXT	External trigger
2	X	N.C
3.20	BIN 7	BIN 7, primary parameter test value within BIN 7 sets range
4.24	BIN 8	BIN 8, primary parameter test value within BIN 8 sets range
5-7	GND	Ground
8	X	N.C
9.13	BIN OUT	BIN OUT, primary parameter test value not in all sets specifications.
10	VEXT	External DC voltage acceptable voltage range is 5V ~ 24V.
11	VINT	Internal DC voltage +5V
12	X	N.C
14	BIN 5	BIN 5, primary parameter test value within BIN 5 sets range
15	BIN 0	BIN 0, secondary parameter test value over the upper, lower sets value
16	BIN 6	BIN 6, primary parameter test value within BIN 6 sets range
17	BIN 1	BIN 1, primary parameter test value within BIN 1 sets range
18	EOT	End of test
19	BIN 2	BIN 2, primary parameter test value within BIN 2 sets range
21	BIN 3	BIN 3, primary parameter test value within BIN 3 sets range
22	ACQ	Analog sampling end, can moving next DUT to 11022 test terminal
23	BIN 4	BIN 4, primary parameter test value within BIN 4 sets range

6.2 Description for Compare Handler Interface Pin

6.2.1 50 Pin

Pin	Name	Description
1-2	VEXT	External DC voltage acceptable voltage range is 5V ~ 24V
3-18	X	N.C
19	/EXT	External trigger
20-21	VEXT	External DC voltage acceptable voltage range is 5V ~ 24V.
22-23	X	N.C
24-25	VINT	Internal DC voltage +5V
26-27	COM	COMMON
28	A HI	Primary parameter test value too high
29	A GO	Primary parameter test value within specification
30	A LO	Primary parameter test value too low
31	B HI	Secondary parameter test value too high
32	B GO	Secondary parameter test value within specification
33	B LO	Secondary parameter test value too low
34	B NG	Secondary parameter test value not in specification
35	GO	Primary and secondary parameter test value within specification
36-37	X	N.C
38	A NG	Primary parameter test value not in specification
39-42	X	N.C
43	ACQ	Analog sampling end, can moving next DUT to 11022 test terminal

44	EOT	End of Test
45-46	COM	COMMON
47-48	X	N.C
49-50	GND	Connect with cover

6.2.2 24 Pin

Pin	Name	Description
1	/EXT	External trigger
2	X	N.C
3.20	A LO	Primary parameter test value too low
4.24	A HI	Primary parameter test value too high
5-7	GND	Ground
8	X	N.C
9.13	A NG	Primary parameter test value not in specification
10	VEXT	External DC voltage acceptable voltage range is 5V ~ 24V.
11	VINT	Internal DC voltage +5V
12	X	N.C
14	B HI	Secondary parameter test value too high
15	B NG	Secondary parameter test value not in specification
16	B LO	Secondary parameter test value too low
17	GO	Primary and secondary parameter test value within specification
18	EOT	End of Test
19	B GO	Secondary parameter test value within specification
21	A GO	Primary parameter test value within specification
22	ACQ	Analog sampling end, can move the next DUT to 11022 test terminal.
23	X	N.C

6.3 Description for Bias Compare Handler Interface Pin

6.3.1 50 Pin

Pin	Name	Description
1-2	VEXT	External DC voltage acceptable voltage range is 5V ~ 24V.
3-18	X	N.C
19	/EXT	External trigger
20-21	VEXT	External DC voltage acceptable voltage range is 5V ~ 24V.
22-23	X	N.C
24-25	VINT	Internal DC voltage +5V
26-27	COM	COMMON
28	O A NG	The original primary parameter value is not in specification.
29	O A GO	The original primary parameter value is in specification.
30	O B NG	The original secondary parameter value is not in specification.
31	O B GO	The original secondary parameter value is in specification.
32	B A NG	The BIAS primary parameter value is not in specification.
33	B A GO	The BIAS primary parameter value is in specification.
34	B B NG	The BIAS secondary parameter value is not in specification.
35	B B GO	The BIAS secondary parameter value is in specification.
36	NG	The original and BIAS primary/secondary test values have one among them not in specification.
37	X	N.C
38	GO	The original and BIAS primary/secondary test values are in specification.
39-42	X	N.C
43	ACQ	Analog sampling end, move the next DUT to 11022 test terminal.
44	EOT	End of Test
45-46	COM	COMMON
47-48	X	N.C
49-50	GND	Connected with cover

6.3.2 24 Pin

Pin	Name	Description
1	/EXT	External trigger
2-4	X	N.C
5-7	COM	COMMON
8	GND	Ground
9	X	N.C
10	VEXT	External DC voltage acceptable voltage range is 5V ~ 24V.
11	VINT	Internal DC voltage +5V
12-17	X	N.C
18	EOT	End of Test
19-24	X	N.C

6.4 Description for Link 1320 Handler Interface Pin

6.4.1 50 Pin

Pin	Name	Description
1-2	VEXT	External DC voltage acceptable voltage range is 5V ~ 24V.
3-4	X	N.C
5	IBCLK	
6	COM	COMMON
7	IBDATA	
8	XB20ARDY	
9	IBSTR	
10	IBIRDY	
11	COM	COMMON
12	XBC1320	
13	VINT	Internal DC voltage +5V
14-19	X	N.C
20-21	VEXT	External DC voltage acceptable voltage range is 5V ~ 24V.
22-23	X	N.C
24-25	VINT	Internal DC voltage +5V
26-27	COM	COMMON
28-44	X	N.C
45-46	COM	COMMON
47-48	X	N.C
49-50	GND	Connected with cover

6.5 Description for Bin99 Groups Handler Interface Pin

Handler interface pins of BIN99 groups are the same as the pins in 6.1 *Description for Binning Handler Interface Pin*. The data type used in the section is the string with binary 8 bits to represent the judgment BIN number currently. BIN 1~BIN 8 stand for bits in binary string respectively. BIN 1 stands for Least Significant Bit (LSB) and BIN 8 stands for Most Significant Bit (MSB). The high output active voltage is about +5V as well as low output active voltage is about 0V. For example, BIN number is judged as "50" *i.e.* the DUT's test value meets to binning setting of the fiftieth group. The binary string data for outputting in Handler interface is "00110010". The output results of 50 Pin Handler interface are as below table.

Pin Description	BIN 8	BIN 7	BIN 6	BIN 5	BIN 4	BIN 3	BIN 2	BIN 1
Pin No.	28	30	33	31	36	29	32	35
Bit Status	0	0	1	1	0	0	1	0

The output results of another 24 Pin Handler interface are as below table.

Pin Description	BIN 8	BIN 7	BIN 6	BIN 5	BIN 4	BIN 3	BIN 2	BIN 1
Pin No.	4, 24	3, 20	16	14	23	21	19	17
Bit Status	0	0	1	1	0	0	1	0

The secondary parameter will over high/low limit setting value if BIN number is judged as "0". Therefore, the binary string data is "00000000" outputted by Handler interface. The primary parameter test value isn't in all setting specifications if BIN result is judged as "OUT". Thus, the binary string data is "01100100" outputted by Handler interface. About output results of 50 Pin Handler and 24 Pin Handler interfaces, please refer above tables.

6.6 Handler Interface Description of Dual Frequency (Option)

6.6.1 50 Pin

Pin	Signal Name	Description
1-2	VEXT	External DC voltage acceptable voltage range is 5V ~ 24V.
3-18	X N.	C
19	/EXT	External trigger
20-21	VEXT	External DC voltage acceptable voltage range is 5V ~ 24V.
22-23	X N.	C
24-25	VINT	Internal DC voltage +5V
26-27	COM	COMMON
28	SFQ GO	The secondary parameter test value with second frequency is in setting range.
29	BIN 3	The primary parameter test value is in BIN 3 setting range.
30	SFQ NOGO	The secondary parameter test value with second frequency is out of setting range.
31	FFQ NOGO	The secondary parameter test value with first frequency is out of setting range.
32	BIN 2	The primary parameter test value is in BIN 2 setting range.
33	FFQ GO	The secondary parameter test value with first frequency is in setting range.
34	X	N.C
35	BIN 1	The primary parameter test value is in BIN 1 setting range.
36	BIN 4	The primary parameter test value is in BIN 4 setting range.
37	X	
38	BIN OUT	The primary parameter test value is out of all setting specifications.
39-42	X	N.C
43	ACQ	Analog sampling end, move the next DUT to 11022 test terminal
44	EOT	End of Test
45-46	COM	COMMON
47-48	X	N.C
49-50	GND	Connected with cover

Note : Binning of primary and secondary parameter is tested respectively. BIN1~BIN4 and BIN OUT are primary parameter binning signal. NOGO and GO are secondary parameter binning signal.

6.6.2 24 Pin

Pin	Signal Name	Description
1	/EXT	External trigger
2	X	N.C
3, 20	SFQ NOGO	The secondary parameter test value with second frequency is out of setting range
4, 24	SFQ GO	The secondary parameter test value with second frequency is in setting range
5-7	GND	Grounding
8	X	N.C
9, 13	BIN OUT	The primary parameter test value is out of all setting specifications
10	VEXT	External DC voltage acceptable voltage range is 5V ~ 24V.
11	VINT	Internal DC voltage +5V
12	X	N.C
14	FFQ NOGO	The secondary parameter test value with first frequency is out of setting range.
15	X	N.C
16	FFQ GO	The secondary parameter test value with first frequency is in setting range.
17	BIN 1	The primary parameter test value is in BIN 1 setting range.
18	EOT	End of Test
19	BIN 2	The primary parameter test value is in BIN 2 setting range.
21	BIN 3	The primary parameter test value is in BIN 3 setting range.
22	ACQ	Analog sampling end, move the next DUT to 11022 test terminal
23	BIN 4	The primary parameter test value is in BIN 4 setting range.

Note : Binning of primary and secondary parameter is tested respectively. BIN1~BIN4 and BIN OUT are primary parameter binning signal. NOGO and GO are secondary parameter binning signal.

6.7 Timing Relation of Handler Interface Control Signal

6.7.1 Setting without Trigger Delay Time (Freq. \geq 100Hz)

Set Trigger Edge to Falling state in system parameter operation then set INTEG. CYCLE to a cycle. The test frequency is being to above 100Hz and fixes measurement range. The test time doesn't include DCR function or measurements of 50Hz and 60Hz test frequencies. Timing Relation of Handler Interface Control Signal is shown as below figure. About the definitions of /EXT, ACQ, EOT and BIN signals please see pin description for Handler interface.

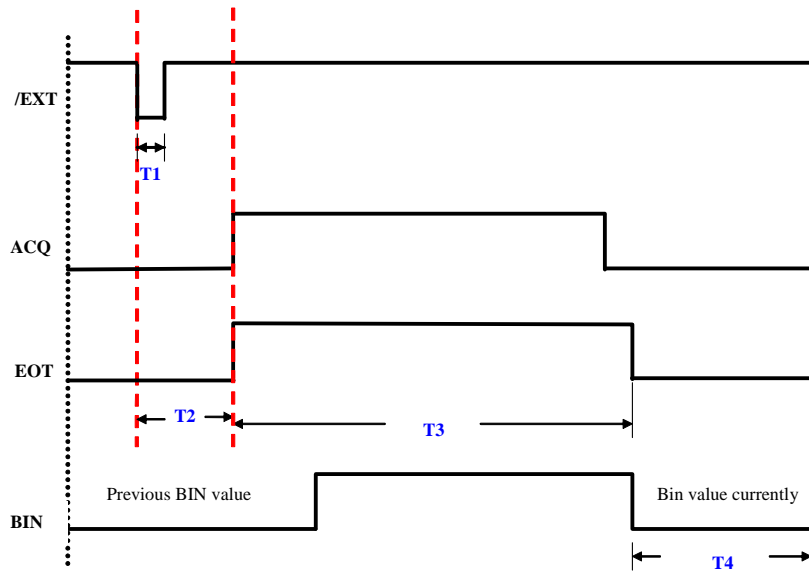

Measurement Speed		FAST	MEDIUM	SLOW
Measurement Time	T1 ≥	1.25μs	1.25μs	1.25μs
	T2 <	1ms	1ms	1ms
	T3 <	21ms	51ms	360ms

Set Trigger Edge to Rising state in system parameter operation then set INTEG. CYCLE to a cycle. The test frequency is being to above 100Hz and fixes measurement range. The test time doesn't include DCR function or measurements of 50Hz and 60Hz test frequencies. Timing Relation of Handler Interface Control Signal is shown as below figure. About the definitions of /EXT, ACQ, EOT and BIN signals please see pin description for Handler interface.

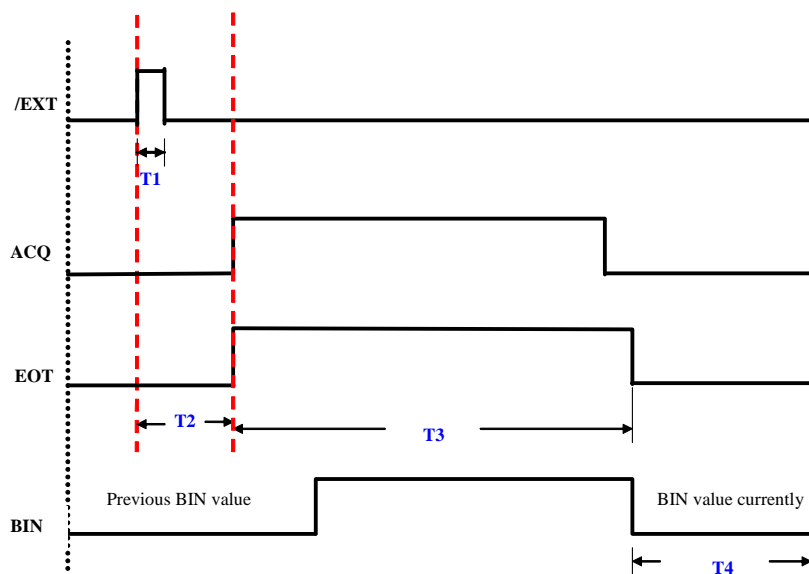

Measurement Speed		FAST	MEDIUM	SLOW
Measurement Time	T1 ≥	1.25μs	1.25μs	1.25μs
	T2 <	1ms	1ms	1ms
	T3 <	21ms	51ms	360ms

6.7.2 Setting with Trigger Delay Time (Freq. ≥ 100Hz)

Set Trigger Edge to Falling state in system parameter operation then set INTEG. CYCLE to a cycle. The test frequency is being to above 100Hz and fixes measurement range. The test time doesn't include DCR function or measurements of 50Hz and 60Hz test frequencies. When Trigger Delay time is T_{DELAY} , Timing Relation of Handler Interface Control Signal is shown as below figure. About the definitions of /EXT, ACQ, EOT and BIN signals please see pin description for Handler interface.

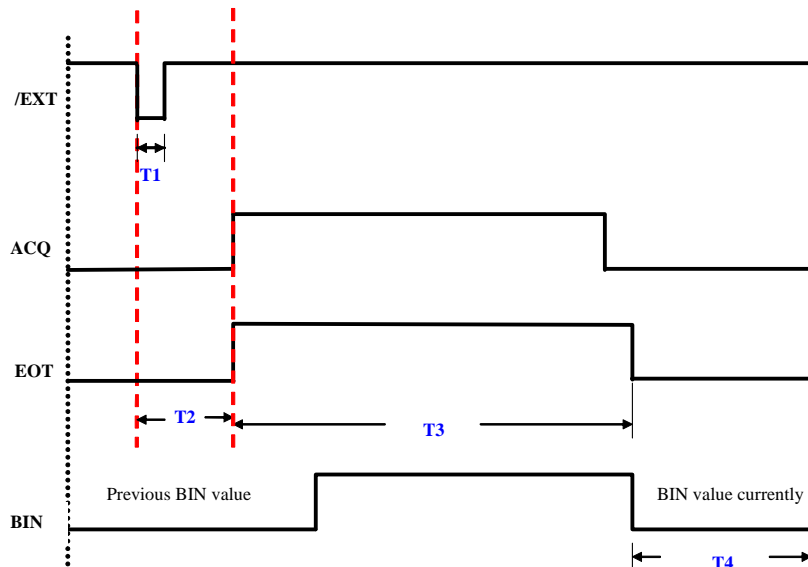

Measurement Speed		FAST	MEDIUM	SLOW
Measurement Time	T1 ≥	1.25μs	1.25μs	1.25μs
	T2 <	1ms	1ms	1ms
	T3 <	$(21+T_{DELAY})$ ms	$(51+T_{DELAY})$ ms	$(360+T_{DELAY})$ ms

Set Trigger Edge to Rising state in system parameter operation then set INTEG. CYCLE to a cycle. The test frequency is being to above 100Hz and fixes measurement range. The test time doesn't include DCR function or measurements of 50Hz and 60Hz test frequencies. When Trigger Delay time is T_{DELAY} , Timing Relation of Handler Interface Control Signal is shown as below figure. About the definitions of /EXT, ACQ, EOT and BIN signals please see pin description for Handler interface.

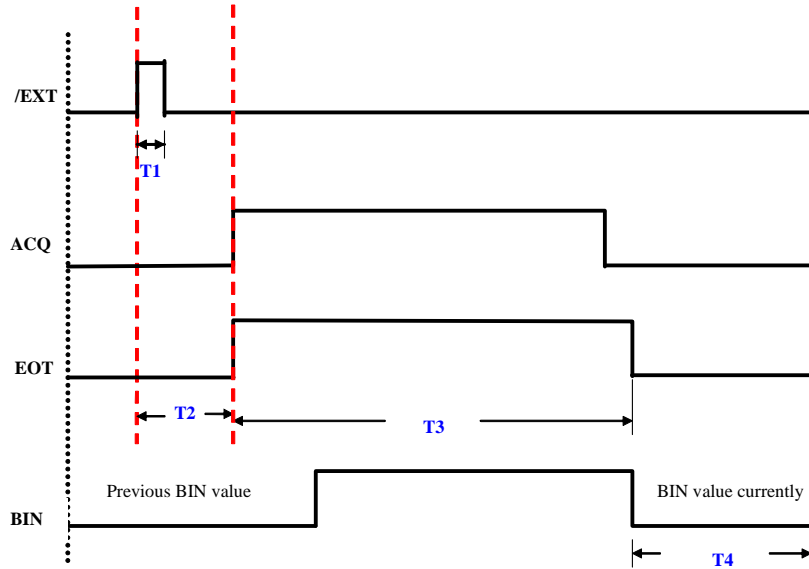

Measurement Speed		FAST	MEDIUM	SLOW
Measurement Time	T1 ≥	1.25μs	1.25μs	1.25μs
	T2 <	1ms	1ms	1ms
	T3 <	(21+T _{DELAY}) ms	(51+T _{DELAY}) ms	(360+T _{DELAY}) ms

T1 is /EXT external trigger signal, this external trigger time should be more than 1.25μs to ensure receiver circuit is received.

T2 is the time of trigger to execution measurement, it less than or equal to 1ms.

T3 is EOT measurement end time. When EOT turns from Lo (0V) to Hi (+5V), it means starting measurement. When EOT turns from Hi (+5V) to Lo (0V), it means measurement data had been calculated so that can read the values as well as perform the next measurement.

T4 is normally Hi (+5V) for judging BIN. When T4 is judged as a certain BIN, thus this signal will follow EOT signal turns from Hi (+5V) to Lo (0V) and remains it until the next measurement then turns to Hi (+5V).

Appendix A Optional Accessory

A110211 Component Test Fixture

This fixture is specially designed for testing DIP passive component impedance. It adopts 4-terminal measured method which can test resistance range extensively. DIP passive component suitable maximum pitch is evaluated as 73mm and minimum pitch is 5mm. There is also a switching rack for axial lead type devices used.



A110212 Component Remote Test Fixture

This fixture is specially designed for testing DIP passive component impedance. The test method is similar to A110211 component test fixture to add 1m length test cable for the convenience of testing. DIP passive component suitable maximum pitch is evaluated as 73mm and minimum pitch is 5mm. There is also switching stand for axial lead type devices used.



A110104 SMD Test Cable

This cable is specially designed for testing SMD passive component impedance. SMD passive component suitable minimum dimension is evaluated as 1.6mm (length) × 0.8mm (width) and maximum dimension is evaluated as 10mm at the longest side. Tweezers contacts on the clamp are for fixing the DUT.



A110232 4 BNC Test Cable

This cable is specially designed for DUTs with unique test point shape which can't use traditional clamp for testing. It also adopts 4-terminal measured method and adds a grounding wire to enhance the stability of low impedance component testing. The contact maximum dimension of passive component is evaluated as 10mm.



A133004 SMD Test Box

This box is specially designed for testing SMD passive component impedance. The minimum dimension of SMD passive component is evaluated as 1.0mm (length) × 0.5mm (width). The maximum width is evaluated as 12mm.

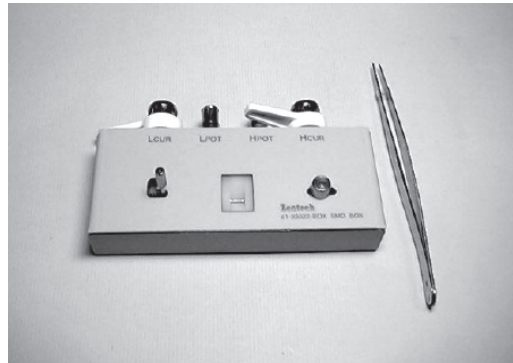

A110239 SMD Test Box

This box is specially designed for testing SMD electrolytic capacitor impedance. It is equipped with positioning function to adopt 4-terminal measured method. The maximum fixture rated voltage is 35V, the maximum rated currents are DC 100mA and AC 100mA. The DUT minimum dimension is evaluated as 3mm and maximum dimension is evaluated as 10mm. The rest are evaluated as more suitable dimensions are 4mm, 5mm, 6.3mm and 8mm respectively.

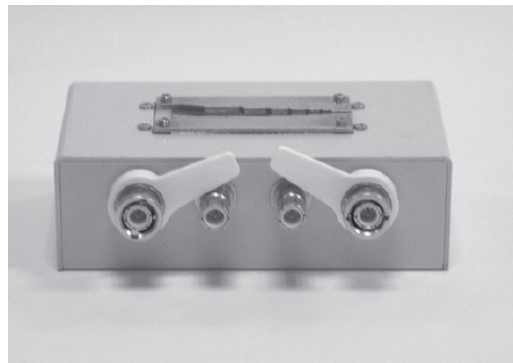

A110236 Rack Mountain Kit

This kit is specially designed for Chroma LCR 11022 fixes on large-sized system rack conveniently such as Chroma 8800 ATS system.



A110242 Battery ESR Test Kit

This kit is specially designed for testing high capacitance capacitor which can isolate remained DC voltage in capacitor to enhance the accuracy of testing. The maximum rated voltage on Hcur terminal is DC 100V; the maximum rated voltage on Hpot and Lpot terminals are DC ±100V.

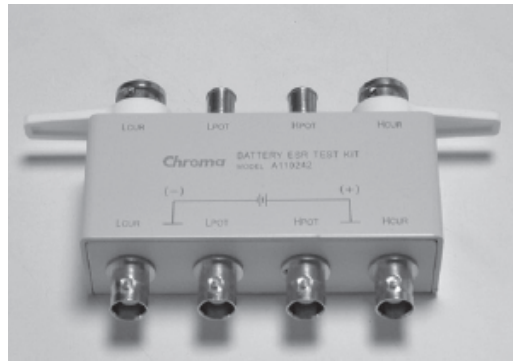

A110244 High Capacitance Capacitor Test Fixture

This fixture is specially designed for testing high capacitance capacitor. High capacitance capacitor junction is M5 screw hole and outer diameter over 6mm. The DUT is with very low impedance when clip the junction by using test clamp isn't easy to be fixed. Thus, test cable should be contacted and fixed well. It also adopts 4-terminal measured method. This fixture rated voltage is 35V, rated currents are DC 100mA and AC 100mA and junction pitch is $12.00 \pm 0.5\text{mm}$ $\sim 46.00 \pm 0.5\text{mm}$.

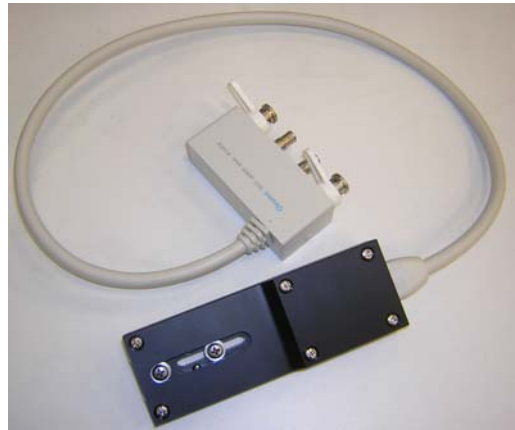

A110245 Ring Core Test Fixture

This fixture is specially designed for testing low inductance ring core. It also adopts 4-terminal measured method. The maximum outer diameter of ring core is evaluated as 78mm, the maximum inner diameter is evaluated as 1.2mm and the maximum height is evaluated as 18mm.

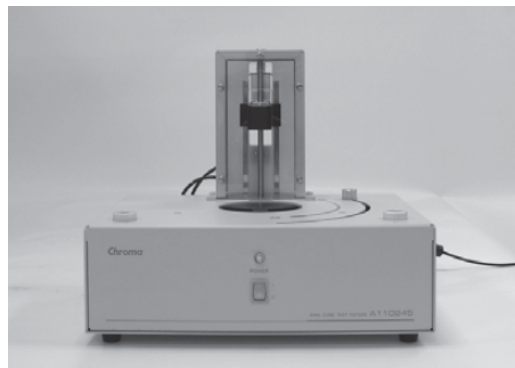

A132574 DC-DC Power Choke SMD Test Box

This box is specially designed for testing DC feature of SMD Power Choke component. It also adopts 4-terminal measured method. The maximum operating current is 1 A. The maximum dimension of DUT is evaluated as $18\text{mm} \times 15\text{mm}$ and the minimum dimension is evaluated as $5\text{mm} \times 5\text{mm}$ as well as the solder pin $\geq 1\text{mm} \times 1\text{mm}$ is recommended. For the customers' convenience to take DUT by the method of vacuum drawing DUT. Capable of selecting DUT to coordinate with optional equipment A113012 Vacuum Generator or A113014 Vacuum Pump.





CHROMA ATE INC.

致茂電子股份有限公司

66 Hwaya 1st Rd.

Kuei-shan Hwaya Technology Park

Taoyuan County 33383, Taiwan

33383 台灣桃園縣龜山鄉

華亞科技園區華亞一路 66 號

T +886-3-327-9999

F +886-3-327-8898

Mail: info@chromaate.com

<http://www.chromaate.com>